



DZIRE

SUPPLEMENTARY OWNER'S MANUAL FOR VEHICLE FITTED WITH CNG FUEL SYSTEM

Use this Supplementary Owner's manual
along with Owner's manual

Refer for vehicle usage at all times.
Contains important information on Safety, Operation & Maintenance.

Part No. 99011M55UC0-74W
December, 2024 (ENG.)

NOTE:

- **As per Government regulation, CNG cylinder needs to be checked and certified every THREE (3) YEARS from the date of initial testing as mentioned on the CNG cylinder identification plate. Customer has to present the vehicle to a government approved testing agency.**
- **As per Government regulation, CNG cylinder has to be discarded at 20 YEARS from the date of initial testing as mentioned in the CNG cylinder identification plate. Customer has to discard the cylinder at his / her expense through government approved scrap agencies.**
- **DO NOT reuse the cylinder valve, once it is replaced / removed from cylinder assembly.**

CONTENTS

INTRODUCTION TO CNG	1
SAFETY PRECAUTIONS (Do's and Don'ts)	1
LAYOUT OF THE CNG SYSTEM	2
FUEL MODES	3
SELECTOR SWITCH POSITION	3
PETROL MODE.....	3
AUTO MODE	3
FORCED CNG MODE.....	4
AUTOMATIC CHANGEOVER	
FROM CNG MODE TO PETROL MODE	4
CNG LEVEL INDICATOR.....	4
CNG FILLER VALVE	5
CNG CYLINDER.....	5
CNG CYLINDER WARNING LABEL	5
MANUAL SHUT-OFF VALVE.....	6
MANUAL SHUT-OFF VALVE OPERATION.....	6
LIST OF GOVERNMENT APPROVED CNG	
CYLINDER TESTING STATIONS	7
SPARE WHEEL LOCATION.....	7
JACK REMOVAL PROCEDURE	7
SPARE WHEEL REMOVAL PROCEDURE	8
INSTRUMENT CLUSTER.....	9
CNG MALFUNCTION WARNING LAMP	10
CNG LOW FUEL WARNING LIGHT.....	10
CNG KIT IDENTIFICATION	10
CNG WARNING LABEL	11
FUSES	11
PERIODIC MAINTENANCE SCHEDULE	12
SPECIFICATIONS.....	13

FIRE EXTINGUISHER	14
LOCATION	14
PARTS DESCRIPTION	14
REMOVAL PROCEDURE.....	15
PROCEDURE OF OPERATION	15
FITMENT PROCEDURE	16
REFILLING SCHEDULES.....	16

FOR VEHICLES FITTED WITH CNG FUEL SYSTEM

INTRODUCTION TO CNG

CNG (Compressed Natural Gas) is principally constituted by methane. CNG is considered as clean burning fuel. Due to low density of CNG, it is compressed at a pressure of around 200 bars to enhance the vehicle on-board storage capacity.

CAUTION

In case of any symptom of CNG leakage or releasing noise or any external damage to CNG piping or during accident, do not panic.

- **Stop the vehicle and switch off the engine, roll down the windows and open all the doors.**
- **Ensure to close manual shut off valve.**
- **Contact Maruti Suzuki authorized workshop immediately for further assistance.**

SAFETY PRECAUTIONS

Do's

1. If any service or body repair is to be carried out, turn the manual shut off valve on CNG cylinder valve to close position prior to commencement of the repair work.
2. Get the CNG cylinder checked every three (3) years from the date of last testing / retesting of cylinder by government authorized CNG cylinder testing agency.
3. If the vehicle does not changeover to CNG in AUTO MODE, then have your vehicle checked by Maruti Suzuki authorized workshop at the earliest.
4. Switch "OFF" engine while fuel filling (CNG/Petrol).
5. After refueling CNG or Petrol, ensure that the CNG fuel filler valve cover is closed (Other-wise vehicle cannot be started).
6. In AUTO MODE, It is programmed to start the vehicle in petrol and automatically shift to CNG based on the engine temperature etc. Do not press the accelerator pedal to change from petrol to CNG.

Don'ts

1. Do not change/modify the configuration, settings or the components from CNG system.
2. The CNG cylinder should not be repaired under any circumstances, in case of any problem, consult with Maruti Suzuki authorized workshop.
3. Do not adjust setting of CNG system.
4. Never install LPG or any other gas cylinder in place of CNG cylinder.
5. Avoid carrying inflammable material near the CNG cylinder.
6. Do not fill any other type of gas other than CNG.
7. Do not press the accelerator pedal to change from petrol to CNG MODE.

FOR VEHICLES FITTED WITH CNG FUEL SYSTEM

LAYOUT OF THE CNG SYSTEM

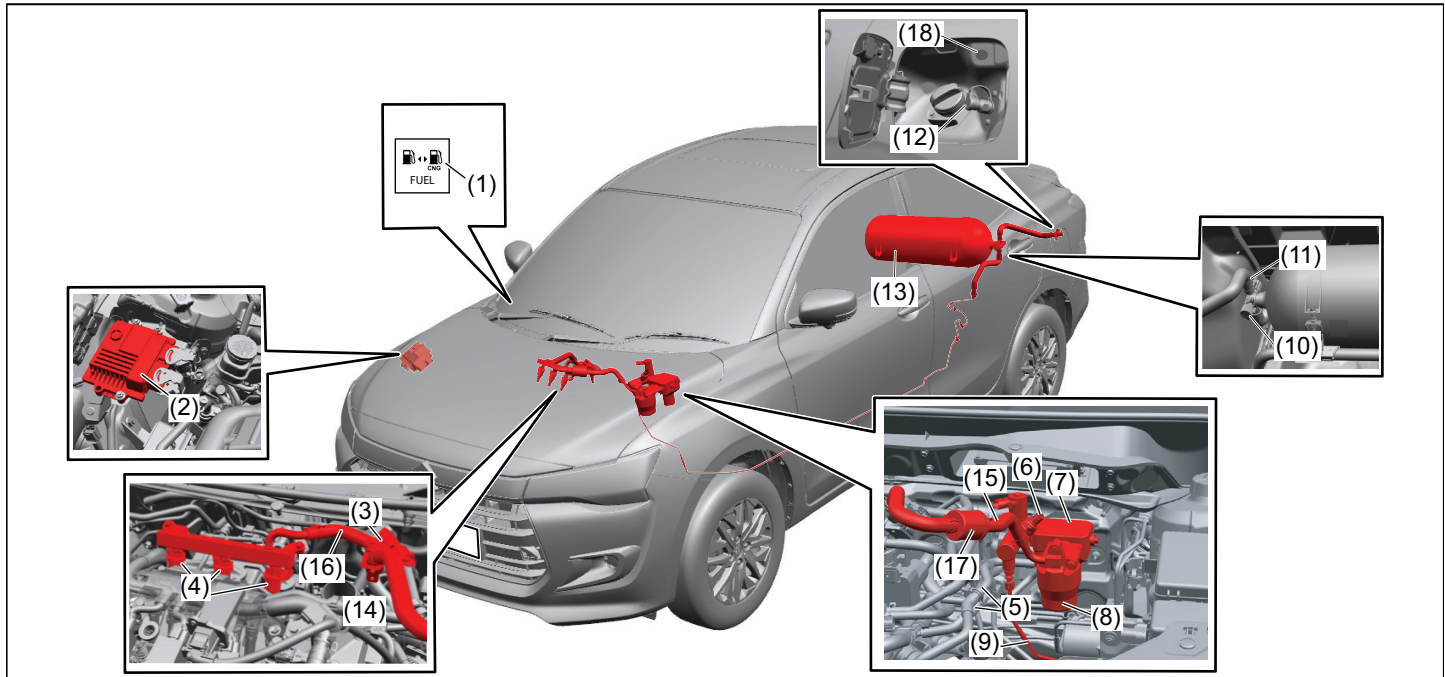

55UMC0002

- | | | |
|---------------------------------------|------------------------------------|---|
| (1) Changeover / Selector switch | (7) Pressure regulator | (14) Low pressure CNG hose (chamber to pipe comp) |
| (2) CNG controller | (8) CNG filter | (15) Low pressure CNG hose (filter to chamber) |
| (3) Low pressure & temperature sensor | (9) High pressure pipe | (16) Low pressure CNG hose (pipe comp to rail) |
| (4) CNG injectors | (10) CNG cylinder valve | (17) Chamber |
| (5) Water hose | (11) Vent hose | (18) Fuel lid switch |
| (6) High pressure sensor | (12) CNG Receptacle / Filler valve | |
| | (13) CNG cylinder | |

FOR VEHICLES FITTED WITH CNG FUEL SYSTEM

FUEL MODES

There are three fuel modes in the vehicle (Petrol, Auto and Forced CNG) which are selectable by pressing the selector switch (1) located on the right side of the steering wheel on the dashboard.

⚠ WARNING

Make sure that the parking brake is applied fully and the transmission is in Neutral before attempting to start the engine.

⚠ CAUTION

- Stop turning the starter immediately after the engine has started or the starter system can be damaged.
- Do not crank the engine for more than 12 seconds at a time. If the engine doesn't start on the first try, wait about 30 seconds before trying again.

NOTE:

- Do not press the accelerator pedal to change-over from petrol to CNG mode.
- With ignition switch "ON" and engine not running, blinking of CNG malfunction warning lamp indicates that CNG fuel filler valve cover is open. Vehicle will not start in this condition. For details on CNG malfunction warning lamp, refer to "instrument cluster" section in this manual.

SELECTOR SWITCH POSITION

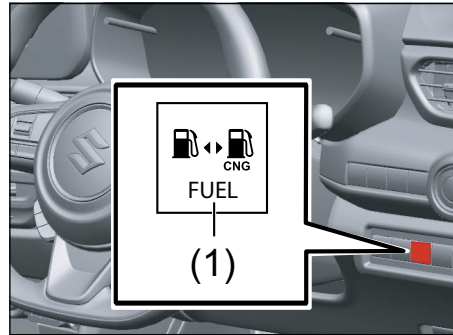

75TM00002

PETROL MODE

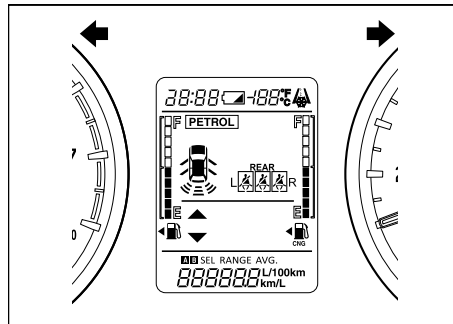

55UMC0003

In this mode vehicle starts in petrol and continue running in petrol mode. In this mode, petrol indicator is continuously displayed and CNG indicator will remain "OFF".

AUTO MODE

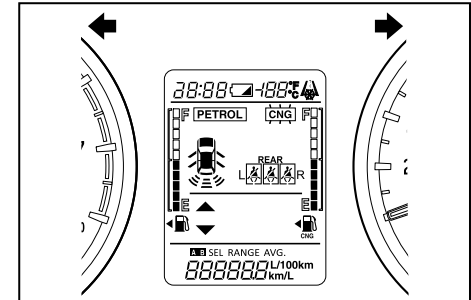

55UMC0004

In this mode engine starts in petrol mode and then automatically changes to CNG after reaching programmed warming up condition. With ignition switch ON and vehicle started in "AUTO MODE", CNG indicator blinks on the display and PETROL indicator is displayed. After change-over to CNG, CNG indicator will be displayed and Petrol indicator will switch OFF automatically.

NOTE:

- It is always recommended to start the vehicle in AUTO MODE or PETROL MODE to enhance the engine life.
- The fuel changeover to CNG may not happen if the vehicle is started when the ambient / engine temperature is below Zero Degree Celsius. In such a case, run the engine in PETROL MODE till it warms up and then try restarting the engine to changeover to CNG.

FORCED CNG MODE

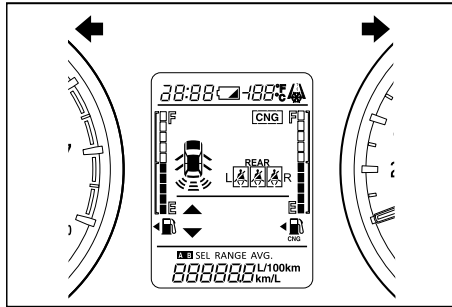

55UMC0005

This is emergency mode and may be used in cases where there is no petrol in petrol tank. In this mode vehicle starts in CNG mode and continues running in CNG mode. With ignition "ON" and engine not running, press and hold the changeover switch till only CNG indicator is displayed. In this mode, CNG indicator is displayed and Petrol indicator remains "OFF".

NOTE:

- It is recommended to keep sufficient amount of petrol in the petrol tank.
- The vehicle may not start in Forced CNG mode if the ambient / engine temperature is below Zero Degree Celsius. It is recommended to start the vehicle in Auto mode.

AUTOMATIC CHANGEOVER FROM CNG MODE TO PETROL MODE

If CNG is finished while the engine is running, vehicle will automatically changeover from CNG mode to Petrol mode & CNG malfunction warning lamp will start blinking. Petrol indicator will be displayed continuously and CNG indicator will switch OFF automatically.

To acknowledge this information, press the changeover switch once. The CNG malfunction warning lamp will stop blinking after the changeover switch is pressed and Petrol indicator will be displayed continuously. However the CNG malfunction indicator lamp will continue to blink after every subsequent Ignition ON - Ignition OFF condition until the vehicle is refilled with CNG.

NOTE:

- It is recommended to keep sufficient amount of petrol in the petrol tank to prevent engine stalling while automatic changeover from CNG mode to Petrol mode.
- In case the CNG malfunction warning lamp does not stop blinking after pressing the changeover switch, take the vehicle to the nearest Maruti Suzuki authorised workshop.

CNG LEVEL INDICATOR

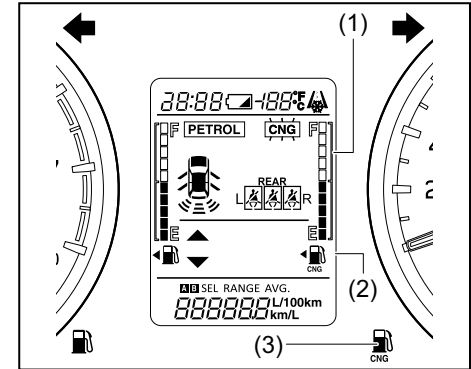

55UMC0006

CNG level indicator (1) is built into the display. When the ignition switch is in the "ON" position, this gauge gives an approximate indication of the quantity of fuel in the fuel tank. "F" stands for full and "E" stands for empty.

If the CNG level meter indicator shows only one segment to "E" refill the CNG tank as soon as possible.

NOTE:

If the CNG low fuel warning light (3) comes on, fill the CNG tank immediately.

The mark (2) indicates that the fuel filler door is located on the right side of the vehicle.

FOR VEHICLES FITTED WITH CNG FUEL SYSTEM

CNG FILLER VALVE

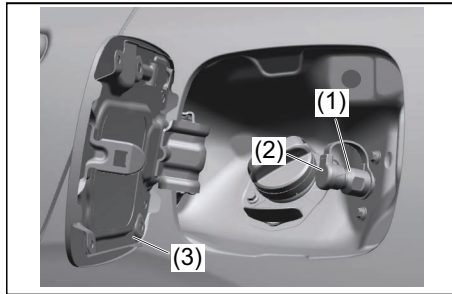

55UMC0007

The CNG filler valve is integrated in fuel box next to petrol fuel filler cap.

CNG filler valve (1) can be uncovered by pulling out the filler valve cover (2) and it can be covered by simply pushing it back.

Filling automatically gets cut off when the cylinder pressure becomes equal to dispenser pressure. After CNG filling, ensure that the filler valve cover (2) and fuel filler lid (3) is closed.

NOTE:

- If the fuel filler lid (3) is kept open, you will not be able to start the vehicle.
- Engine will stop if the fuel filler lid (3) is opened in vehicle stationary condition.

CNG CYLINDER

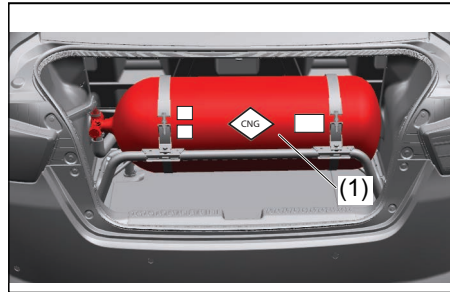

55UMC0008

CNG cylinder (1) is installed in the luggage compartment.

⚠ CAUTION

Do not place any luggage or load over cylinder as it may damage the cylinder, pipe, hose, valve etc.

CNG CYLINDER WARNING LABEL

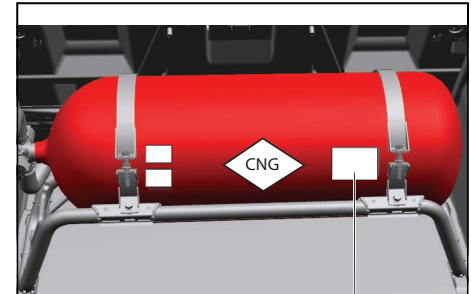

⚠ WARNING

- Do not change the colour of this cylinder.
- Do not fill this cylinder with any other gas than CNG.
- No flammable material should be stored in the close vicinity of this cylinder or in the same room in which it is kept.
- No oil or similar lubricant should be used on the valves or other fittings of this cylinder.
- Have this cylinder tested every 3 years after the date of last test.

55UMC0009

You may find this label on the CNG cylinder.

FOR VEHICLES FITTED WITH CNG FUEL SYSTEM

MANUAL SHUT-OFF VALVE

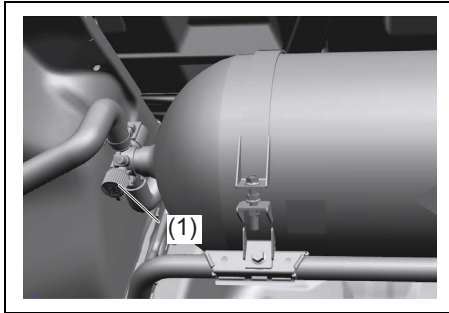

Manual shut-off valve (1) is located on the left hand side of the CNG cylinder.

MANUAL SHUT-OFF VALVE OPERATION

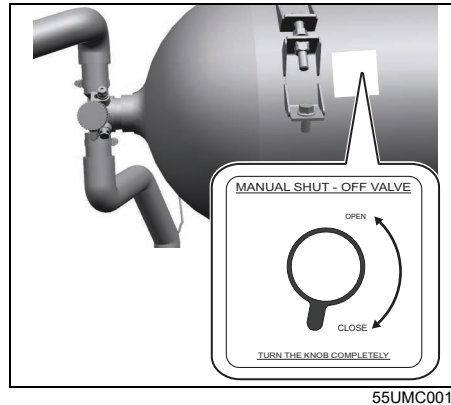
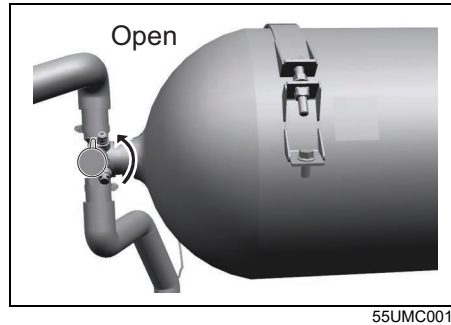
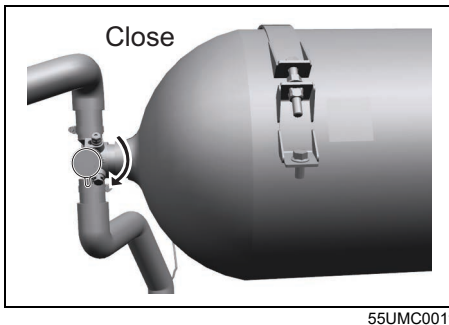

CNG supply can be switched off by closing the manual shut-off valve.

Valve closing: Turn the knob completely in clockwise direction to close the CNG supply to Engine.

Valve opening: Turn the knob completely in anticlockwise direction to open the CNG supply to Engine.

NOTE:

- If the manual shut-off valve is not opened fully, then the engine may not run properly.
- If the manual shut-off valve is in closed condition, it is not possible to fill CNG into the cylinder.

NOTE:

- As per Government regulation, CNG cylinder needs to be checked and certified every three (3) years from the date of initial testing as mentioned on the CNG cylinder identification plate.
- Customer has to present the vehicle to a government approved testing agency.
- Failure to test the cylinder may result in denying of CNG filling by the CNG dispensing stations or may result in confiscating the vehicle by enforcement authorities.
- All the expenses for CNG cylinder testing has to be borne by the customer.
- As per Government regulation, CNG cylinder has to be discarded at 20 years from the date of initial testing as mentioned in the CNG cylinder identification plate.

FOR VEHICLES FITTED WITH CNG FUEL SYSTEM

- Customer has to discard the cylinder at his / her expense through government approved scrap agencies.
- No person shall refill any cylinder, which has been repaired under sub-rule (2) with any gas unless a full report on the repairs and test carried out on the cylinder, accompanied by the repairer's certificate of testing are furnished to the Chief Controller and his permission is obtained for its refilling.

WARNING

- Never remove the cylinder valve from the cylinder assembly. For any assistance consult Maruti Suzuki authorized workshop.
- Never try to clean the cylinder. In case of any problem, contact Maruti Suzuki authorized workshop.
- Do not reuse the cylinder valve, once it is replaced / removed from cylinder assembly.
- Even if the CNG from the cylinder is consumed till engine stops, some amount of CNG will be left out in the tank under pressure.

LIST OF GOVERNMENT APPROVED CNG CYLINDER TESTING STATIONS

To obtain testing stations information visit the following internet website address "www.peso.gov.in"

SPARE WHEEL LOCATION

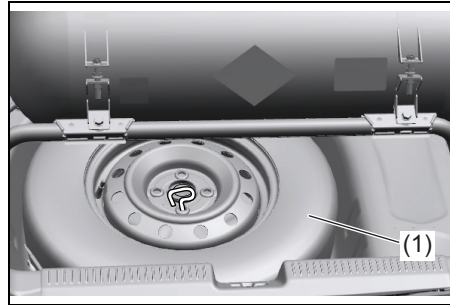

55UMC0018

Spare wheel (1) is located in luggage compartment, placed below the luggage compartment carpet and secured with help of a mounting knob.

JACK REMOVAL PROCEDURE

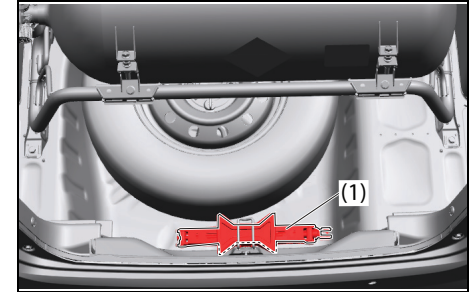

55UMC0012

Jack (1) is located in the luggage compartment, inside carrier spare tyre as shown in illustration.

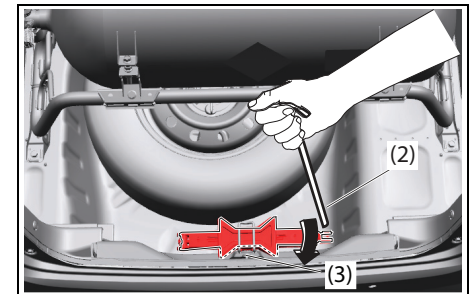

55UMC0013

Remove the jack by rotating the jack shaft anti-clockwise by using jack handle (2) and pull the jack out of the storage bracket (3).

To stow the jack, place it in the storage bracket and turn the shaft clockwise until the jack is securely held in place.

NOTE:

To avoid damaging the storage bracket, do not expand the jack excessively.

CAUTION

Do not place any luggage or load over carrier spare tyre as it may damage the carrier spare tyre or other parts.

SPARE WHEEL REMOVAL PROCEDURE

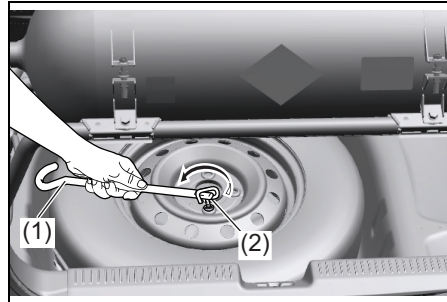

55UMC0019

- (a) Use jack handle (1) to dismount spare wheel.
- (b) Place the jack handle (1) as shown above and rotate in anti-clockwise direction to unlock the mounting knob (2).

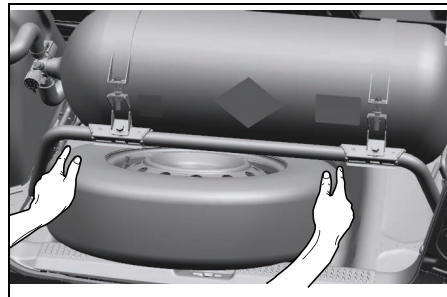

55UMC0020

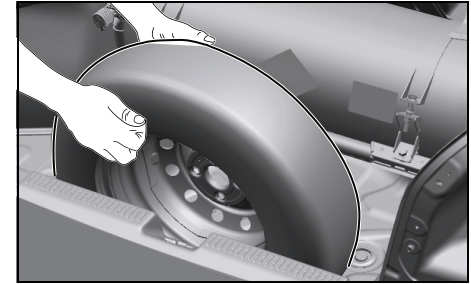

55UMC0021

- (c) Take out the spare wheel by lifting the spare wheel in vertical direction as shown in above.
- (d) Reverse the above procedure for mounting the spare wheel in its position.

NOTE:

Make sure not to damage the trim while removing spare wheel.

FOR VEHICLES FITTED WITH CNG FUEL SYSTEM

INSTRUMENT CLUSTER

- 1) Tachometer
- 2) Speedometer
- 3) CNG low fuel warning light
- 4) CNG malfunction warning indicator lamp
- 5) Indicator selector knob
- 6) Fuel gauge (CNG)
- 7) Fuel gauge (Petrol)
- 8) Trip meter selector knob
- 9) Information display

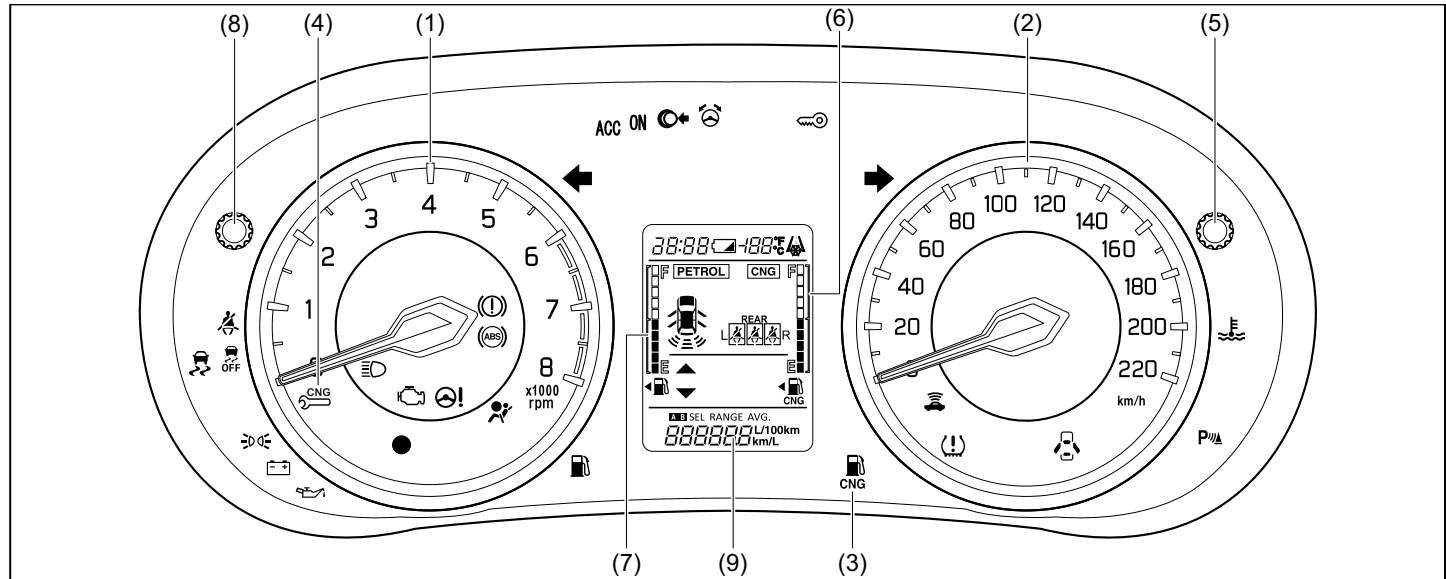

55UMC0001

NOTE:

- When the engine is running on Auto mode or Forced CNG mode, Instantaneous fuel consumption, Average fuel consumption and Driving range information will not be displayed on information display (9).
- If CNG mode is changed to Petrol mode, Instantaneous fuel consumption will appear after few second, whereas Average fuel consumption and Driving range will appear immediately, depending on the display selected.

CNG MALFUNCTION WARNING LAMP

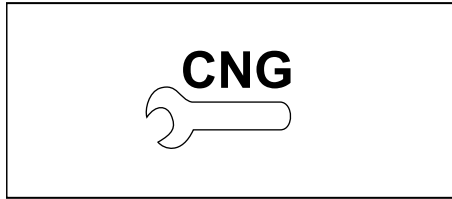

74LM0015

When the ignition switch is turned to “ON” position or the engine switch is pressed to change the ignition mode to ON, this CNG malfunction warning lamp comes on briefly, to check that the CNG malfunction lamp is trouble free.

- If CNG malfunction warning lamp glows continuously, with ignition “ON” there is some problem with the CNG system. Immediately get your vehicle checked by Maruti Suzuki authorized workshop.
- If CNG malfunction warning lamp blinks during engine running, it means there is some problem in CNG system in which vehicle cannot continue running in CNG-MODE and automatically switchover to petrol mode. Have your vehicle checked at Maruti Suzuki authorized workshop.

NOTE:

With ignition switch “ON” and engine not running, blinking of CNG lamp indicates that CNG fuel filler valve cover is open. Vehicle will not start in this condition. Close the CNG Fuel filler valve cover in order to start the vehicle.

CNG LOW FUEL WARNING LIGHT



75TM00016

If this light comes on, fill the CNG tank immediately.

When this light comes on, a ding sounds once to remind you to fill the fuel.

If you do not fill the fuel, a ding sounds every time when the ignition switch is turned to “ON” position or the engine switch is pressed to change the ignition mode to ON.

CNG KIT IDENTIFICATION

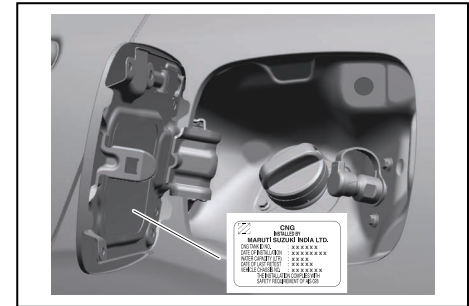

55UMC0014

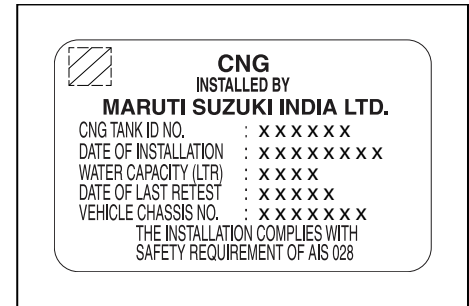

55UMC0024

CNG cylinder identification number and CNG kit installation date is located near the CNG fuel filler valve.

FOR VEHICLES FITTED WITH CNG FUEL SYSTEM

CNG WARNING LABEL

Front Driver Door

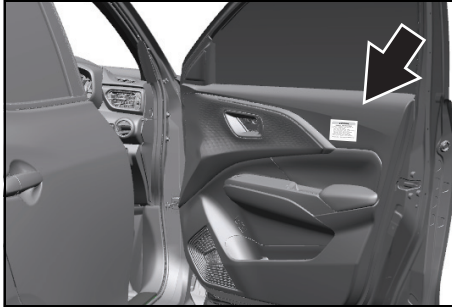

55UMC0015

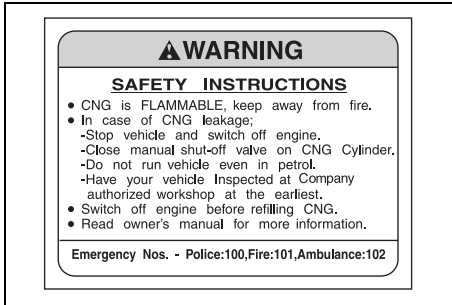

74LM0020

CNG warning label is located on front right door.

FUSES

Fuses in engine compartment

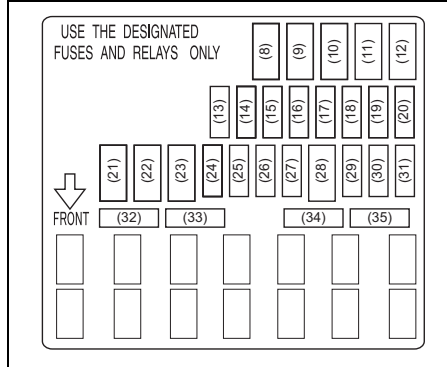

75TM00020

(24)	7.5 A	CNG valve
(32)	7.5 A	CNG
(33)	5 A	CNG IG1

For other fuses, refer “Inspection and maintenance” section in the main owner’s manual.

FOR VEHICLES FITTED WITH CNG FUEL SYSTEM

PERIODIC MAINTENANCE SCHEDULE

Kms (1 x 1000) Month	1	5	10	20	30	40	50	60	70	80	90	100
	1	6	12	24	36	48	60	72	84	96	108	120
Spark plug (CNG)	Replace every 50,000 km or 48 months whichever comes first											
All Joints (Gas leakage)	I	I	I	I	I	I	I	I	I	I	I	I
Coolant Hoses (Leakage, Damage)	I	I	I	I	I	I	I	I	I	I	I	I
All Fasteners Torque values	T	T	T	T	T	T	T	T	T	T	T	T
CNG low pressure filter cartridge with O-Ring	-	-	-	R	-	R	-	R	-	R	-	R
CNG cylinder leak testing and certification	Every 3 years from the date of initial testing by govt. approved testing agency											
CNG filler receptacle O-Ring	Replace every 4 years or 300,000 km, whichever comes earlier											

TTighten to Specified Torque
 I Inspect and correct or replace if necessary
 R Replace

NOTE:

- This table includes services as scheduled up to 100,000 km mileage. Beyond 100,000 km, carry out the same services at the same intervals respectively.
- For other maintenance details refer "Inspection & Maintenance" section in main Owner's Manual.

FOR VEHICLES FITTED WITH CNG FUEL SYSTEM

SPECIFICATIONS

Mass (Weight) (Kgs)	
Kerb Weight	1020 - 1025 Kgs
Gross Weight	1435 Kgs
Seating Capacity	5 persons
Fuel Capacity (litres)	
Petrol	37 L
CNG (Water Filling Capacity)	55 L

NOTE:

Specifications are subject to change without notice.

NOTE:

- 1) *It is recommended to run the vehicle on petrol mode for 5~10 kms after every 300~500 km run in CNG mode to keep fuel system in good condition.*
- 2) *Always keep minimum 5 litres of petrol in your petrol tank.*

FIRE EXTINGUISHER

Do's and Don'ts

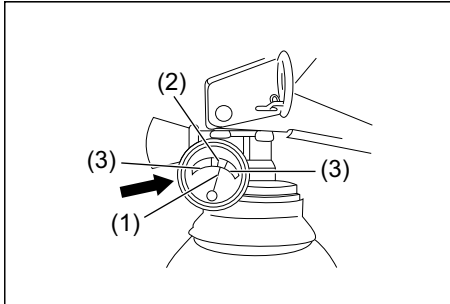

74LM0023

Do's

1. Check pressure gauge periodically. Max charging pressure is 15Kgf/cm² (in green zone (2)).
2. When pressure drops, indicator needle (1) will shift to the red zone (3). Immediately contact the fire extinguisher manufacturer as per the information provided on the fire extinguisher.
3. Get the fire extinguisher serviced only through the manufacturer service centre. Refer the information provided on the fire extinguisher to locate the nearest service centre.
4. Ensure that the Fire extinguisher is always kept at its prescribed position in the vehicle.
5. Refill the fire extinguisher immediately after use.

Don't

- Do not use water for cleaning fire extinguisher (Use clean cloth for removing dust).
- Do not rely on used or discharged fire extinguisher.

LOCATION

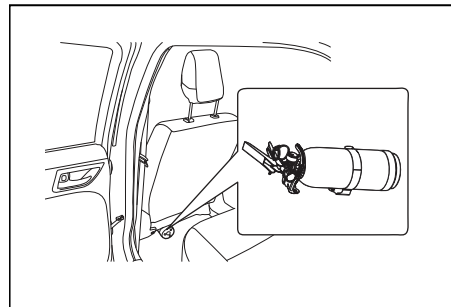

75TM00022

Fire extinguisher is located below co passenger's seat.

PARTS DESCRIPTION

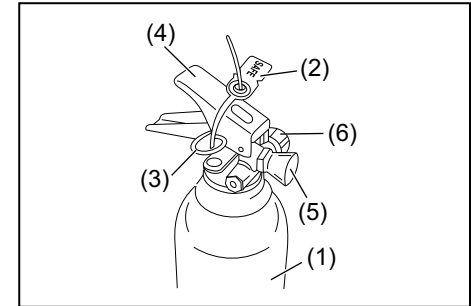

75TM00023

- (1) Fire extinguisher cylinder
- (2) Seal
- (3) Safety Pin
- (4) Lever
- (5) Nozzle
- (6) Pressure gauge

FOR VEHICLES FITTED WITH CNG FUEL SYSTEM

REMOVAL PROCEDURE

Removing from front of co-passenger's seat:

- 1) Pull up the co-passenger's seat position adjustment lever and slide the seat backward to the last position.
- 2) Lift Lever (1) of fire extinguisher slightly upwards and pull the fire extinguisher in the direction as shown in the figure, in order to disengage it from clamps (2).

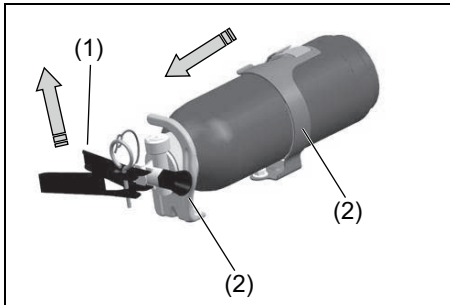

69RM0008

Removing from back side of co-passenger's seat:

- 1) Pull strap (3) in arrow direction as shown in figure to untie the clamp (2).

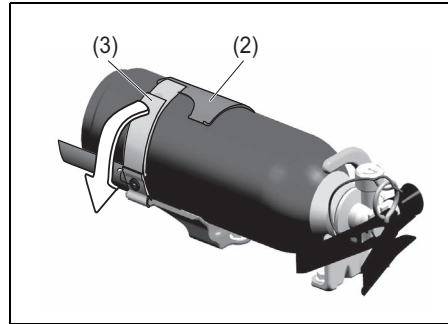

72RMC022

- 2) Remove the fire extinguisher from clamps (2) in the direction as shown in the figure.

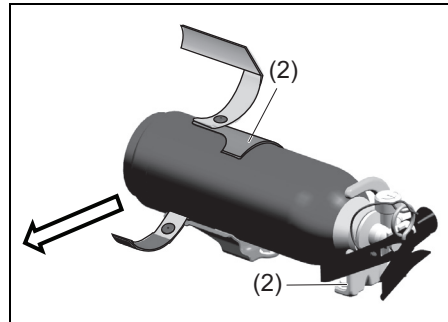

72RMC023

PROCEDURE OF OPERATION

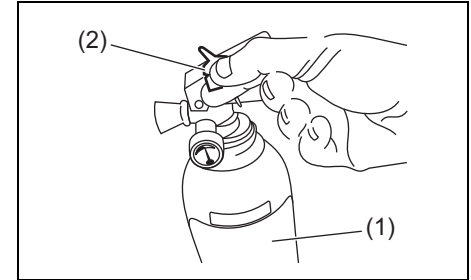

55UMC0022

1. Hold the fire extinguisher (1) upright.
2. Break seal (2) by rotating the safety pin (3).

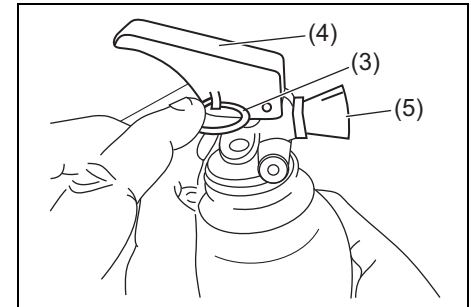

74LM0028

3. Pull Safety pin (3).
4. Squeeze lever (4) and direct the jet from nozzle (5) towards the near edge of the fire with a rapid (fast) sweeping motion.

FOR VEHICLES FITTED WITH CNG FUEL SYSTEM

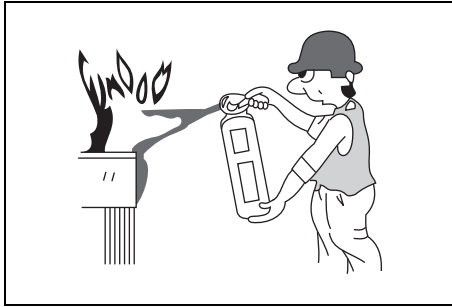

74LM0029

5. Drive the fire towards the far edge until flames are extinguished.

NOTE:

Fire extinguisher is only meant for small fire caused in vehicle by external source only.

FITMENT PROCEDURE

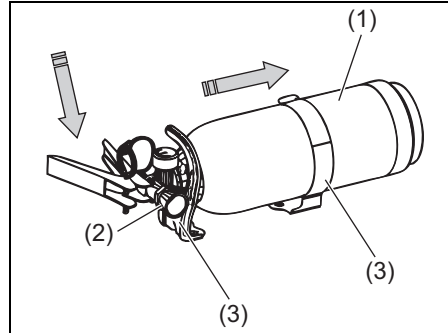

55UMC0023

Insert the body of fire extinguisher (1) in to the clamps (3) and place the nozzle (2) carefully downwards, on the clamp.

NOTE:

Ensure that the nozzle of fire extinguisher is properly seated on the clamp.

REFILLING SCHEDULES

1. Refilling is necessary after every use.
2. Fire extinguisher needs refilling after every 3 years even if it is not used.
3. Get the fire extinguisher inspected every 6 months through the authorised service center of fire extinguisher manufacturer.

Prepared by
MARUTI SUZUKI INDIA LIMITED

Service Division
December, 2024

Part No. 99011M55UC0-74W
Printed in India

**For round-the-clock on-road assistance,
call Maruti On-road Service at 1800 102 1800[#] / 1800 1800 180[#]**

No STD code to be prefixed.

 **MARUTI SUZUKI**
GENUINE ACCESSORIES

 **MARUTI SUZUKI**
GENUINE PARTS

 **MARUTI SUZUKI**
COST PROTECT

 **MARUTI SUZUKI**
HELPLINE

 **MARUTI SUZUKI**
ROAD SERVICE

SERVICE DIVISION

MARUTI SUZUKI INDIA LIMITED

Palam-Gurgaon Road, Gurgaon – 122 015 (Haryana), India

Visit us at: www.marutisuzuki.com



99011M55UC0-74W