

CONTENTS

INTRODUCTION TO CNG.....	3
SAFETY PRECAUTIONS (Do's & Don'ts)	3
LAYOUT OF THE CNG SYSTEM	4
FUEL MODES	5
SELECTOR SWITCH POSITION.....	5
PETROL MODE.....	5
AUTO MODE	5
FORCED CNG MODE.....	6
AUTOMATIC CHANGEOVER FROM CNG MODE TO PETROL MODE.....	6
CNG LEVEL INDICATOR	6
CNG FILLER VALVE.....	7
CNG CYLINDER	7
MANUAL SHUT-OFF VALVE	8
LIST OF GOVERNMENT APPROVED CNG CYLINDER TESTING STATIONS	9
CNG FUSES.....	9
INSTRUMENT CLUSTER.....	9
CNG MALFUNCTION WARNING LAMP	10
CNG KIT IDENTIFICATION	10
CNG WARNING LABEL	10
LIFTING PARTITION GRILL (CARGO)	11
PERIODIC MAINTENANCE SCHEDULE	12
SPECIFICATIONS.....	13
FIRE EXTINGUISHER (if equipped).....	14
PARTS DESCRIPTION.....	15
REMOVAL PROCEDURE	15
PROCEDURE OF OPERATION	15
FITMENT PROCEDURE.....	16
REFILLING SCHEDULES	16



INTRODUCTION TO CNG:

CNG (Compressed Natural Gas) is principally constituted by methane. CNG is considered as clean burning fuel. Due to low density of CNG, it is compressed at a pressure of around 200 bars to enhance the vehicle on-board storage capacity.

CAUTION

In case of any symptom of CNG leakage or releasing noise or any external damage to CNG piping or during accident, do not panic.

- **Stop the vehicle and switch off the engine, roll down the windows and open all the doors**
- **Ensure to close manual shut off valve.**
- **Contact Maruti Suzuki authorized workshop immediatly for further assistance.**

SAFETY PRECAUTIONS (Do's):

1. If any service or body repair is to be carried out, turn the manual shut off valve on CNG cylinder valve to close position prior to commencement of the repair work.
2. Get the CNG cylinder checked every Three (3) years from the date of last testing / retesting of cylinder by government authorized CNG cylinder testing agency.
3. If the vehicle does not changeover to CNG in AUTO MODE, then have your vehicle checked by Maruti Suzuki authorized workshop at the earliest.
4. Switch "OFF" engine while fuel filling (CNG/Petrol).
5. After refueling CNG, ensure that the CNG filler valve cover is closed (Other-wise vehicle cannot be started).
6. In AUTO MODE, It is programmed to start the vehicle in petrol and automatically shift to CNG based on the engine temperature etc. Do not press the accelerator pedal to change from petrol to CNG.

SAFETY PRECAUTIONS (Don'ts):

1. Do not change/modify the configuration, settings or the components from CNG system.
2. The CNG cylinder should not be repaired under any circumstances, in case of any problem, consult with Maruti Suzuki authorized workshop.
3. Do not adjust setting of CNG system.
4. Never install LPG or any other gas cylinder in place of CNG cylinder.
5. Avoid carrying inflammable material near the CNG cylinder.
6. Do not fill any other type of gas other than CNG.
7. Do not press the accelerator pedal to change from petrol to CNG MODE.

FOR VEHICLES FITTED WITH CNG FUEL SYSTEM

LAYOUT OF THE CNG SYSTEM

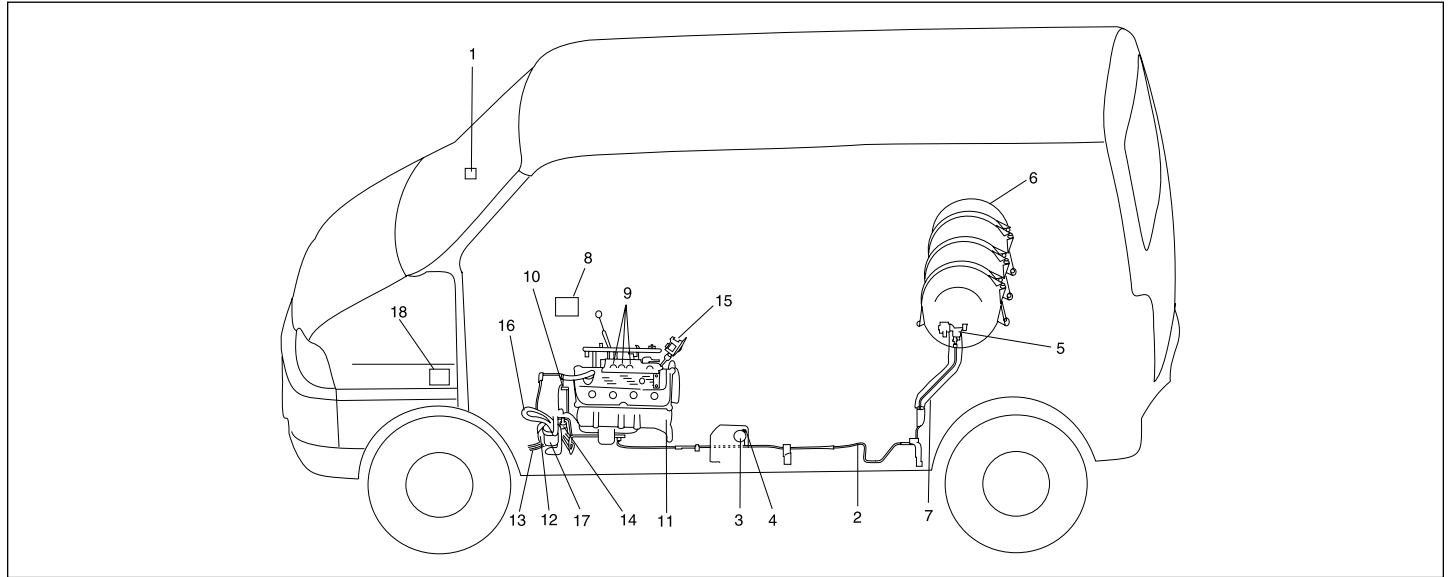

- | | | | | | |
|---|--------------------|----|------------------------------------|----|--------------------------------|
| 1 | Changeover switch | 7 | Vent hose | 13 | Water hose |
| 2 | High pressure pipe | 8 | CNG controller (For Eco passenger) | 14 | High pressure sensor |
| 3 | Receptacle | 9 | CNG injectors | 15 | High pressure gauge |
| 4 | Fuel lid switch | 10 | Low pressure & temperature sensor | 16 | Low pressure hose |
| 5 | CNG cylinder valve | 11 | Engine | 17 | CNG filter |
| 6 | CNG cylinder | 12 | Pressure regulator | 18 | CNG controller (For Eco cargo) |

FUEL MODES

There are three fuel modes in the vehicle (Petrol, Auto and Forced CNG) which are selectable by pressing the selector switch (1) located on the right side of the steering wheel on the dashboard.

⚠ WARNING

Make sure that the parking brake is applied fully and the transmission is in Neutral before attempting to start the engine.

CAUTION

- Stop turning the starter immediately after the engine has started or the starter system can be damaged.
- Do not crank the engine for more than 15 seconds at a time. If the engine doesn't start on the first try, wait about 15 seconds before trying again.

NOTE:

- Do not press the accelerator pedal to changover from petrol to CNG model.
- With ignition switch "ON" and engine not running, blinking of CNG malfunction warning lamp indicates that fuel filler valve cover is not closed properly. Vehicle will not start in this condition.

SELECTOR SWITCH POSITION

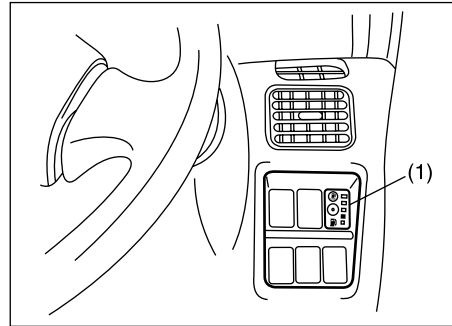

PETROL MODE

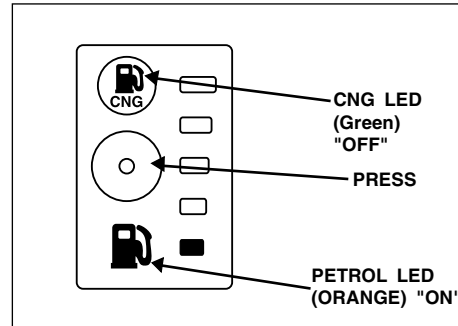

In this mode vehicle starts in petrol and continue running in petrol mode. In this mode, petrol indicator glows continuously in ORANGE color and CNG indicator (GREEN) will remain "OFF".

AUTO MODE

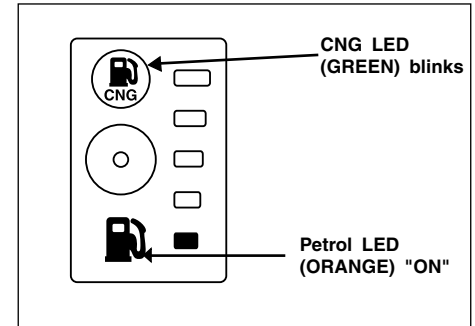

In this mode engine starts in petrol mode and then automatically changes to CNG after reaching programmed warming up condition. With ignition switch ON and vehicle started in "AUTO MODE", CNG indicator blinks (Green Color), and PETROL indicator glows (Orange color) continuously. After changeover to CNG, CNG indicator will glow continuously and PETROL indicator switches OFF automatically.

NOTE:

- It is always recommended to start the vehicle in AUTO MODE or PETROL MODE to enhance the engine life.
- The fuel changeover to CNG may not happen if the vehicle is started when the ambient / engine temperature is below Zero Degree Celsius. In such a case,

FOR VEHICLES FITTED WITH CNG FUEL SYSTEM

run the engine in PETROL MODE till it warms up and then try restarting the engine to changeover to CNG.

FORCED CNG MODE (Emergency use Only)

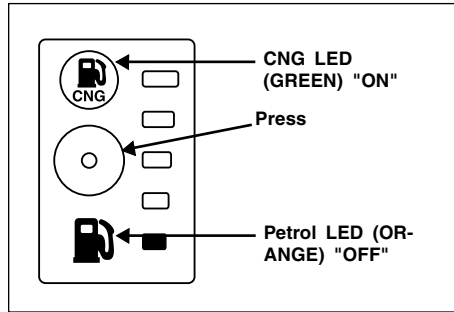

This is emergency mode and may be used in cases where there is no petrol in petrol tank. In this mode vehicle starts in CNG and continues running in CNG mode. With ignition "ON" and engine not running, press and hold the changeover switch till CNG indicator glows continuously. In this mode, CNG indicator glows continuously in GREEN color and Petrol indicator (ORANGE) remains "OFF".

NOTE:

- It is recommended to keep sufficient amount of petrol in the petrol tank and refill it periodically.

- The vehicle may not start in Forced CNG mode if the ambient / engine temperature is below Zero Degree Celsius. It is recommended to start the vehicle in Auto mode.

AUTOMATIC CHANGEOVER FROM CNG MODE TO PETROL MODE

If CNG is finished while the engine is running, vehicle will automatically change over from CNG mode to Petrol mode & CNG malfunction warning lamp will start blinking. Petrol indicator (ORANGE color) will glow continuously and CNG indicator (GREEN color) will switch OFF automatically.

To acknowledge this information, press the changeover switch once. The CNG malfunction warning lamp will stop blinking after the changeover switch is pressed and Petrol indicator (ORANGE color) will glow continuously.

NOTE:

- It is recommended to keep sufficient amount of petrol in the petrol tank to prevent engine stalling while automatic changeover from CNG mode to Petrol mode.
- In case the CNG malfunction warning lamp does not stop blinking after pressing the changeover switch, take the vehicle to the nearest MARUTI SUZUKI dealer.

CNG LEVEL INDICATOR (On Dashboard)

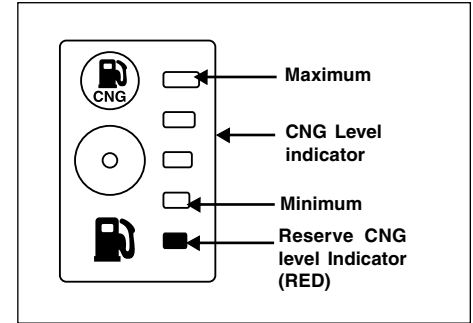

CNG level indicator is built into the changeover switch. It consists of four green and one red LEDs, which indicates approximate amount / level of remaining CNG in the cylinder. Red LED of CNG level indicator glows when reaches to reserve quantity.

NOTE:

- When CNG reserve level indicator glows, refill CNG as soon as possible.

CNG FILLER VALVE

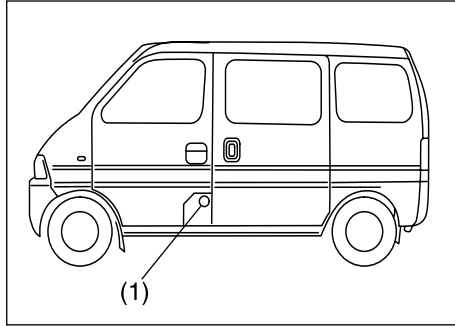

The CNG filler valve (1) is located on the left side of vehicle outboard.

CNG filler valve (1) can be unlocked by pulling out the Filler valve cover (2) and can be covered by simply pushing it back.

Filling automatically gets cut off when the cylinder pressure becomes equal to dispenser pressure. After CNG filling, ensure that the filler valve cover (2) is closed.

Note:

- If the Fuel filler cover (2) is not closed properly, you will not be able to start the vehicle.
- Engine will stop if the fuel filler cover (2) is opened in vehicle stationary condition.

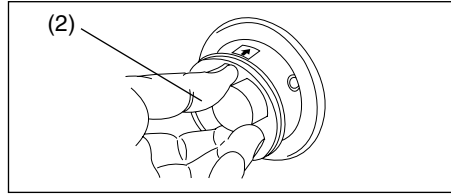

CNG CYLINDER

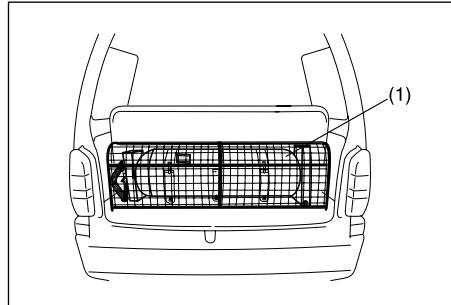

CNG cylinder (1) is installed in the luggage compartment, and is covered with protective cage (if equipped)

CAUTION

Do not sit or carry items luggage or load on the top of cylinder cage, even if items are small & light. Objects on the top of the cage could be thrown about in case of accident, causing injury or obstruct the driver's rear view. Cylinder cage may also get damaged.

CNG CYLINDER WARNING LABEL

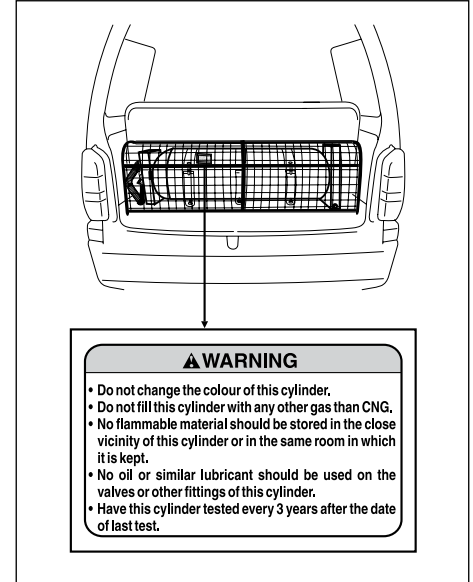

You may find this label on the CNG cylinder.

▲ WARNING

- Do not change the colour of this cylinder.
- Do not fill this cylinder with any other gas than CNG.
- No flammable material should be stored in the close vicinity of this cylinder or in the same room in which it is kept.
- No oil or similar lubricant should be used on the valves or other fittings of this cylinder.
- Have this cylinder tested every 3 years after the date of last test.

FOR VEHICLES FITTED WITH CNG FUEL SYSTEM

MANUAL SHUT-OFF VALVE

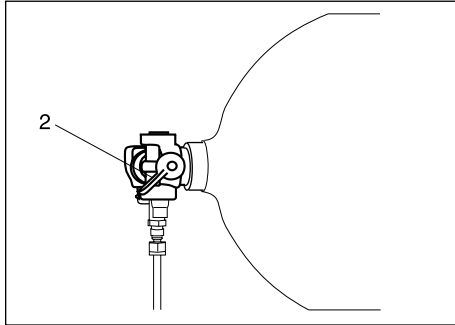

Manual shut-off valve (2) is located on the left hand side of the CNG cylinder.

MANUAL SHUT-OFF VALVE OPERATION

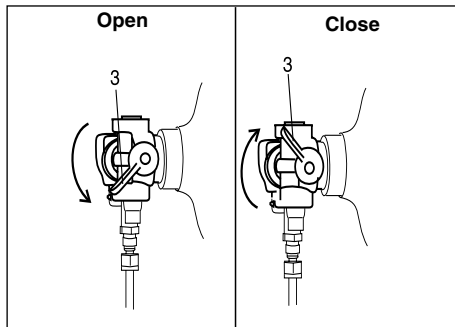

CNG supply can be switched off by closing the manual shutoff valve.

Valve closing: Turn the knob completely in clockwise direction to close the CNG supply to Engine.

Valve opening: Turn the knob completely in anti-clockwise direction to open the CNG supply to Engine.

Note:

- If the manual shut-off valve is not opened fully, then the engine may not run properly.
- If the manual shut-off valve is in closed condition, it is not possible to fill CNG into the cylinder.

Note:

- As per Government regulation, CNG cylinder needs to be checked and certified every three (3) years from the date of initial testing as mentioned on the CNG cylinder identification plate.
- Customer has to present the vehicle to a government approved testing agency.
- Failure to test the cylinder may result in denying of CNG filling by the CNG dispensing stations or may result in confiscating the vehicle by enforcement authorities.
- All the expenses for CNG cylinder testing has to be borne by the customer.

- As per Government regulation, CNG cylinder has to be discarded at 20 years from the date of initial testing as mentioned in the CNG cylinder identification plate.
- Customer has to discard the cylinder at his / her expense through government approved scrap agencies.
- No person shall refill any cylinder, which has been repaired under sub-rule (2) with any gas unless a full report on the repairs and test carried out on the cylinder, accompanied by the repairer's certificate of testing are furnished to the Chief Controller and his permission is obtained for its refilling.

⚠ WARNING

- **Never remove the cylinder valve from the cylinder assembly. For any assistance consult Maruti Suzuki authorized workshop.**
- **Never try to clean the cylinder. In case of any problem, contact Maruti Suzuki authorized workshop.**
- **Do not reuse the cylinder valve, once it is replaced / removed from cylinder assembly.**
- **Even if the CNG from the cylinder is consumed till engine stops, some amount of CNG will be left out in the tank under pressure.**

LIST OF APPROVED CNG CYLINDERS TESTING STATIONS

To obtain testing stations information visit the following internet website address :
 “www.peso.gov.in”

CNG FUSES

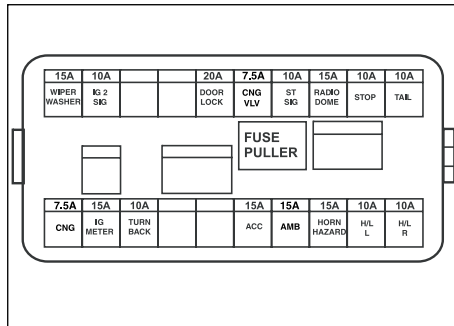

INSTRUMENT CLUSTER

- 1) Speedometer
- 2) Odometer / Tripmeter
- 3) Odometer / Tripmeter selector knob
- 4) Other warning & indicator lamps
- 5) Fuel Indicator
- 6) CNG malfunction warning Indicator lamp

EXAMPLE

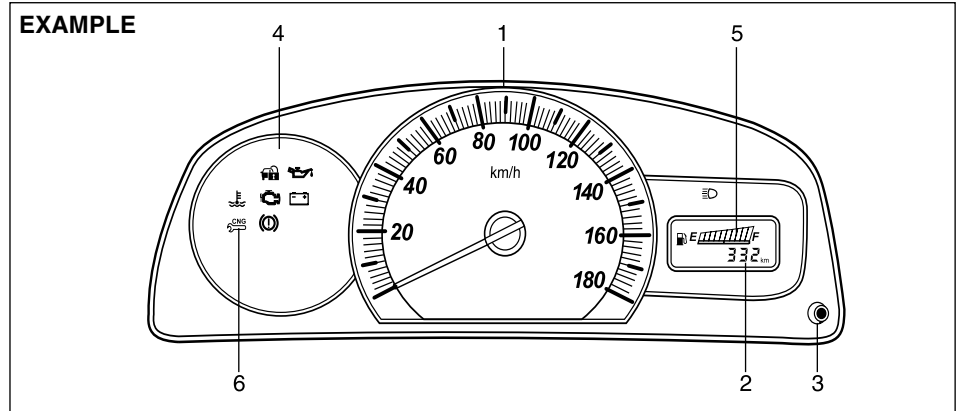

FOR VEHICLES FITTED WITH CNG FUEL SYSTEM

CNG MALFUNCTION WARNING LAMP

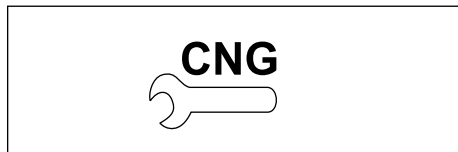

When the ignition switch is turned "ON", this CNG malfunction warning lamp comes on briefly, to check that the CNG system is troublefree.

- If CNG malfunction warning lamp glows continuously, with ignition "ON" there is some problem with the CNG system. Immediately get your vehicle checked by Maruti Suzuki authorized workshop.
- If CNG malfunction warning lamp blinks during engine running, it means there is some problem in CNG system in which vehicle cannot continue running on CNG MODE and automatically switchover to petrol mode. Have your vehicle checked at Maruti Suzuki authorized workshop.

In case of Automatic switchover from CNG to Petrol when CNG gas is finished, CNG malfunction warning lamp also blinks. Please refer to section "AUTOMATIC CHANGEOVER FROM CNG MODE TO PETROL MODE"

NOTE:

With ignition switch "ON" and engine not running, blinking of CNG lamp indicates that CNG filler valve cover is open. Vehicle will not start in this condition. Close CNG filler valve cover in order to start the vehicle.

CNG KIT IDENTIFICATION

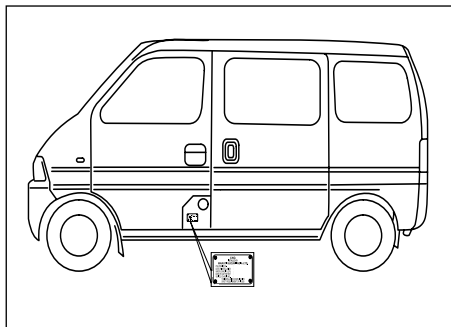

CNG cylinder identification number and CNG kit installation date is located below CNG filler valve as shown.

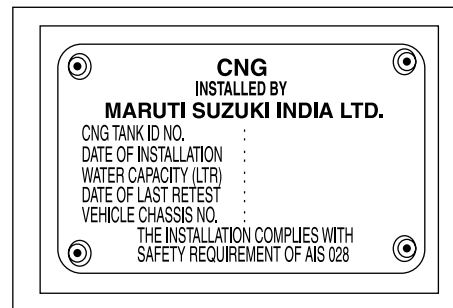

CNG WARNING LABEL

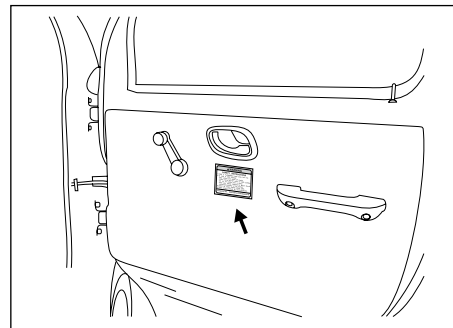

Front Driver door

LIFTING PARTITION GRILL (CARGO)

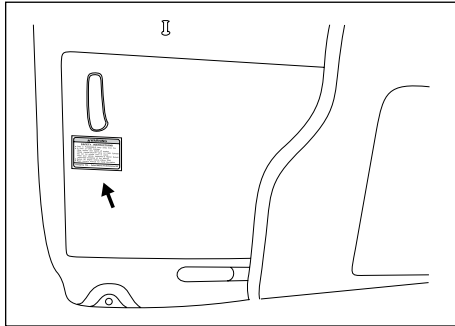

Rear Slide Door (Right Side)

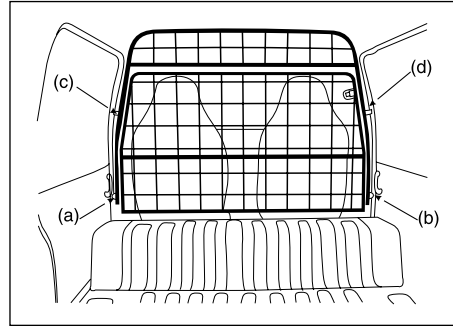

There are four locking points for partition grill (a), (b), (c) and (d)

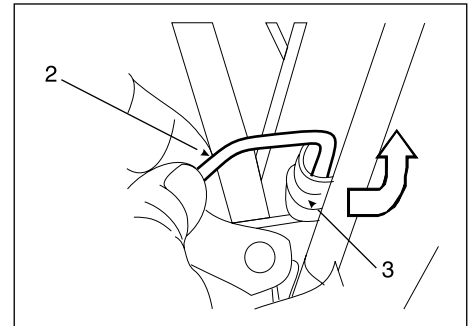

Disengage bracket (2) from clamp (3) by lifting it upwards

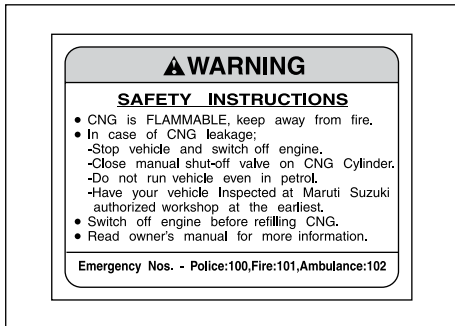

CNG warning label is located on front and rear RH doors.

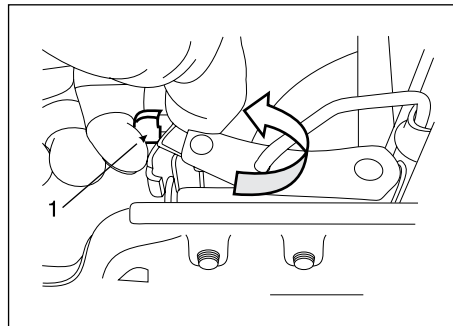

Lift lever (1) located at four points (a), (b), (c) and (d)

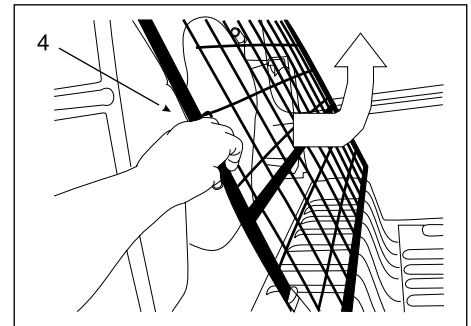

Partition (4) can be raised by lifting upwards as shown in figure.

FOR VEHICLES FITTED WITH CNG FUEL SYSTEM

PERIODIC MAINTENANCE SCHEDULE

Kms (1 x 1000) Month	1	5	10	20	30	40	50	60	70	80	90	100
	1	6	12	24	36	48	60	72	84	96	108	120
All Joints (Gas leakage)	I	I	I	I	I	I	I	I	I	I	I	I
Coolant Hoses (Leakage, Damage)	I	I	I	I	I	I	I	I	I	I	I	I
All Fasteners Torque values	T	T	T	T	T	T	T	T	T	T	T	T
CNG reducer filter cartridge with O-Ring	-	-	-	-	-	R	-	-	-	R	-	-
CNG low pressure filter cartridge with O-Ring	-	-	-	R	-	R	-	R	-	R	-	R
CNG cylinder leak testing and certification	Every 3 years from the date of initial testing by govt. approved testing agency											
CNG filler receptacle O-Ring	Replace every 4 years or 300,000 Km, whichever comes earlier											

TTighten to Specified Torque

I.....Inspect and correct or replace if necessary

R.....Replace

Note:

This table includes services as scheduled up to 100,000 km mileage. Beyond 100,000 km, carry out the same services at the same intervals respectively.

For other maintenance details refer "Inspection & Maintenance" section in main Owner's Manual.

SPECIFICATIONS

Mass (Weight) (Kgs)	Passenger	Cargo
Kerb Weight	1010-1040 Kgs	1000 Kgs
Gross Weight	1510 Kgs	1540 Kgs
Seating Capacity	5 persons	2 Persons
Fuel Capacity (litres)		
Petrol	40 L	
CNG (Water Filling Capacity)	65 L	

NOTE:

Specifications are subject to change without notice.

NOTE:

- 1) *It is recommended to run the vehicle on petrol mode for 5-10 kms after every 300-500 km run in CNG mode to keep fuel system in good condition.*
- 2) *Always keep minimum 5 litres of petrol in your petrol tank.*
- 3) *For others specifications refer main Owner's Manual provided along with the vehicle.*

FOR VEHICLES FITTED WITH CNG FUEL SYSTEM

FIRE EXTINGUISHER (if equipped)

Do's and Don'ts

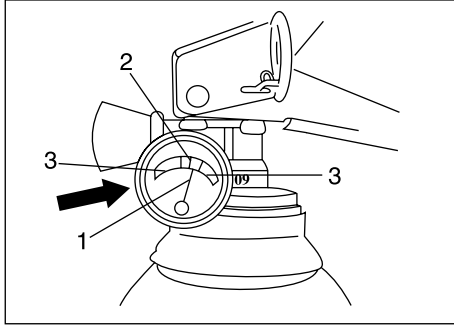

Do's

1. Check pressure gauge periodically. Max charging pressure is 15Kgf/cm² (in green zone (2)).
2. When pressure drops, indicator needle (1) will shift to the red zone (3). Immediately contact the fire extinguisher manufacturer as per the information provided on the fire extinguisher.
3. Get the fire extinguisher serviced, only through the manufacturer service centre. Refer the information provided on the fire extinguisher to locate the nearest service centre.
4. Ensure that the Fire extinguisher is always kept at its prescribed position in the vehicle.

5. Refill the fire extinguisher immediately after use.

Don't

1. Do not use water for cleaning fire extinguisher. (Use clean cloth for removing dust)
2. Do not rely on used or discharged fire extinguisher.

LOCATION (IN CARGO)

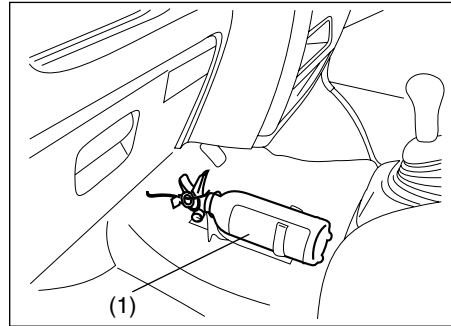

Fire extinguisher (1) is located between driver's and co-passenger as shown.

LOCATION (IN PASSENGER)

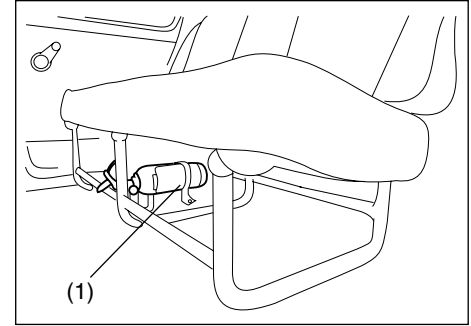

Fire extinguisher (1) is located below the rear seat as shown.

PARTS DESCRIPTION

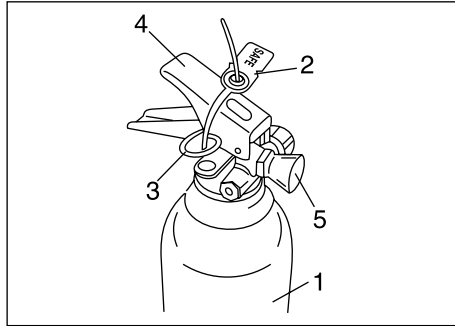

- 1) Fire extinguisher cylinder
- 2) Seal
- 3) Safety Pin
- 4) Lever
- 5) Nozzle

REMOVAL PROCEDURE

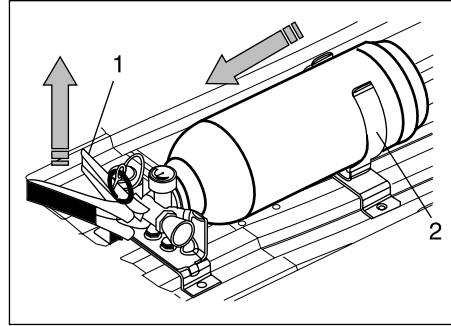

Lift Lever (1) of fire extinguisher slightly upwards and pull the fire extinguisher in the direction as shown in the figure, in order to disengage it from clamp (2).

PROCEDURE OF OPERATION

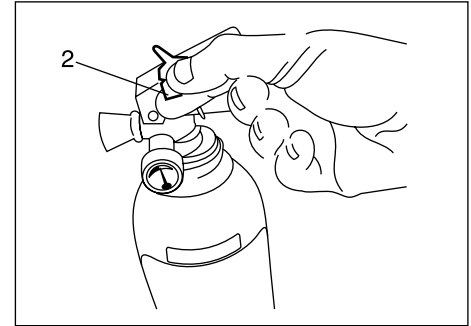

1. Hold the fire extinguisher (1) upright.
2. Break seal (2) by rotating the safety pin (3).

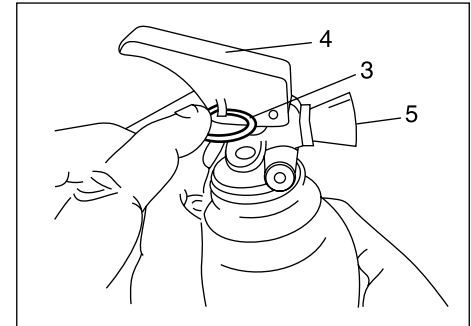

3. Pull Safety pin (3)

FITMENT PROCEDURE

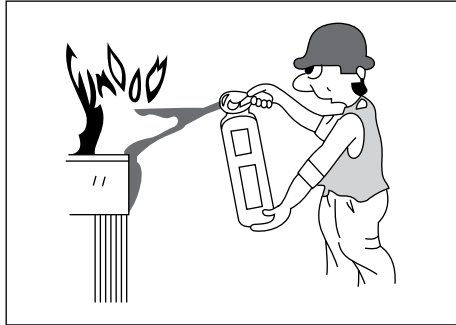

4. Squeeze lever (4) and direct the jet from nozzle (5) towards the fire with a rapid (fast) sweeping motion.
5. Drive the fire towards the far edge until flames are extinguished.

NOTE:

Fire extinguisher is only meant for small fire caused in vehicle by external source only.

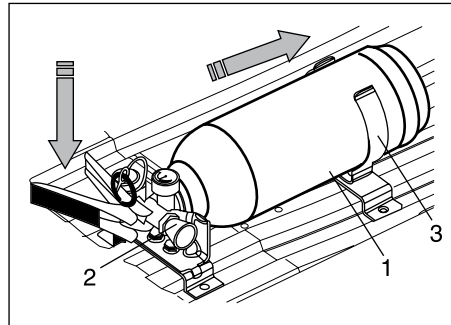

Insert the body of fire extinguisher (1) in to the clamp (3) and place the nozzle (2) carefully downwards, on the clamp

NOTE:

Ensure that the nozzle of fire extinguisher is properly seated on the clamp.

REFILLING SCHEDULES

1. Refilling is necessary after every use.
2. Fire extinguisher needs refilling after every 3 years even if it is not used.
3. Inspect every 6 month by the manufacturer authorised service centre.