



# *DZIRE*

## SUPPLEMENTARY OWNER'S MANUAL FOR VEHICLE FITTED WITH CNG FUEL SYSTEM

Use this Supplementary Owner's manual  
along with Owner's manual and Service booklet

Keep the booklet with the vehicle at all times.

Contains important information on Safety, Operation & Maintenance.

Part No. 99011M56RC0-74E  
March, 2022 (ENG)

**NOTE:**

- **As per Government regulation, CNG cylinder needs to be checked and certified every THREE (3) YEARS from the date of initial testing as mentioned on the CNG cylinder identification plate. Customer has to present the vehicle to a government approved testing agency.**
- **As per Government regulation, CNG cylinder has to be discarded at 20 YEARS from the date of initial testing as mentioned in the CNG cylinder identification plate. Customer has to discard the cylinder at his / her expense through government approved scrap agencies.**
- **DO NOT reuse the cylinder valve, once it is replaced / removed from cylinder assembly.**

---

# CONTENTS

INTRODUCTION TO CNG .....	1
SAFETY PRECAUTIONS (Do's and Don'ts) .....	1
LAYOUT OF THE CNG SYSTEM .....	2
FUEL MODES .....	3
SELECTOR SWITCH POSITION .....	3
PETROL MODE.....	3
AUTO MODE .....	3
FORCED CNG MODE.....	4
AUTOMATIC CHANGEOVER	
FROM CNG MODE TO PETROL MODE .....	4
CNG LEVEL INDICATOR.....	4
CNG FILLER VALVE .....	5
CNG CYLINDER.....	5
CNG CYLINDER WARNING LABEL .....	5
MANUAL SHUT-OFF VALVE.....	6
MANUAL SHUT-OFF VALVE OPERATION.....	6
LIST OF GOVERNMENT APPROVED CNG	
CYLINDER TESTING STATIONS .....	7
SPARE WHEEL LOCATION .....	7
JACK REMOVAL PROCEDURE .....	7
SPARE WHEEL REMOVAL PROCEDURE .....	7
INSTRUMENT CLUSTER.....	8
CNG MALFUNCTION WARNING LAMP.....	9
CNG LOW FUEL WARNING LIGHT.....	9
CNG KIT IDENTIFICATION.....	9
CNG WARNING LABEL .....	10
FUSE BOX.....	10
PERIODIC MAINTENANCE SCHEDULE .....	13
SPECIFICATIONS.....	14

FIRE EXTINGUISHER .....	15
LOCATION .....	15
PARTS DESCRIPTION .....	15
REMOVAL PROCEDURE.....	16
PROCEDURE OF OPERATION .....	16
FITMENT PROCEDURE .....	17
REFILLING SCHEDULES.....	17

## FOR VEHICLES FITTED WITH CNG FUEL SYSTEM

---

### INTRODUCTION TO CNG

CNG (Compressed Natural Gas) is principally constituted by methane. CNG is considered as clean burning fuel. Due to low density of CNG, it is compressed at a pressure of around 200 bars to enhance the vehicle on-board storage capacity.

#### CAUTION

**In case of any symptom of CNG leakage or releasing noise or any external damage to CNG piping or during accident, do not panic.**

- **Stop the vehicle and switch off the engine, roll down the windows and open all the doors.**
- **Ensure to close manual shut off valve.**
- **Contact Maruti Suzuki authorized workshop immediatly for further assistance.**

### SAFETY PRECAUTIONS

#### Do's

1. If any service or body repair is to be carried out, turn the manual shut off valve on CNG cylinder valve to close position prior to commencement of there pair work.
2. Get the CNG cylinder checked every three (3) years from the date of last testing / retesting of cylinder by government authorized CNG cylinder testing agency.
3. If the vehicle does not changeover to CNG in AUTO MODE, then have your vehicle checked by Maruti Suzuki authorized workshop at the earliest.
4. Switch "OFF" engine while fuel filling (CNG/Petrol).
5. After refueling CNG or Petrol, ensure that the CNG fuel filler valve cover is closed (Other-wise vehicle cannot be started).
6. In AUTO MODE, It is programmed to start the vehicle in petrol and automatically shift to CNG based on the engine temperature etc. Do not press the accelerator pedal to change from petrol to CNG.

#### Don'ts

1. Do not change/modify the configuration, settings or the components from CNG system.
2. The CNG cylinder should not be repaired under any circumstances, in case of any problem, consult with Maruti Suzuki authorized workshop.
3. Do not adjust setting of CNG system.
4. Never install LPG or any other gas cylinder in place of CNG cylinder.
5. Avoid carrying inflammable material near the CNG cylinder.
6. Do not fill any other type of gas other than CNG.
7. Do not press the accelerator pedal to change from petrol to CNG MODE.

LAYOUT OF THE CNG SYSTEM

EXAMPLE

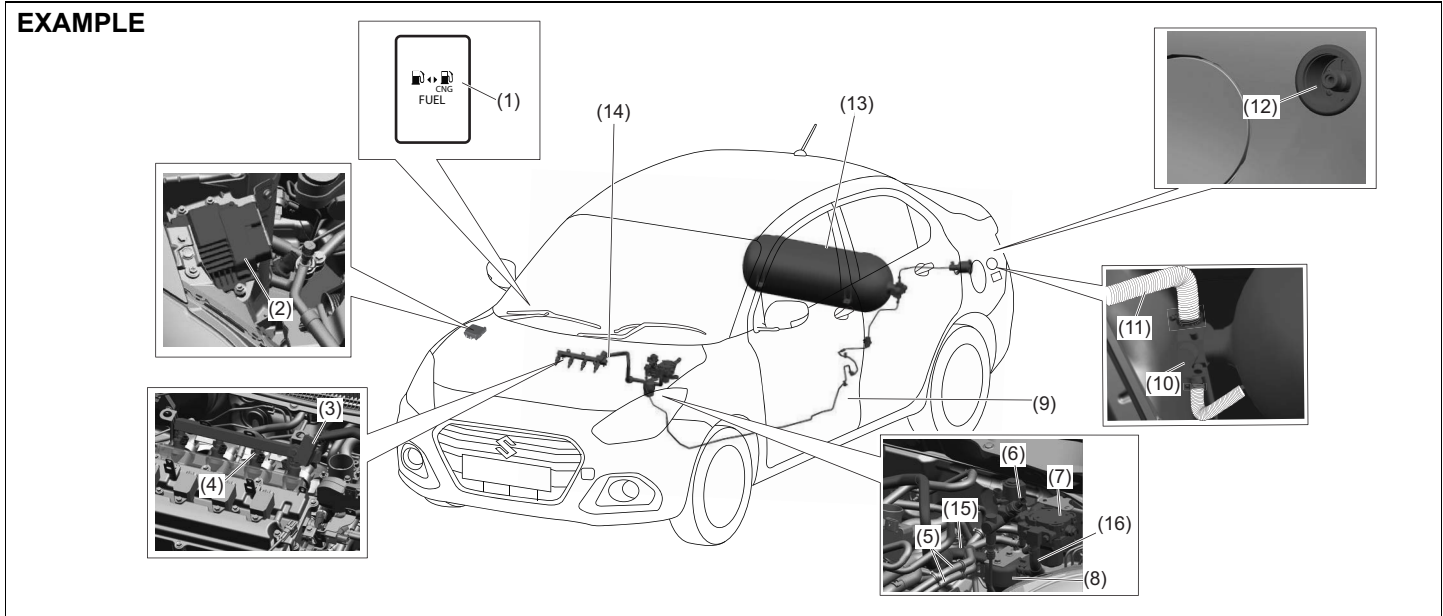

56RM0001

- |                                       |                         |   |
|---------------------------------------|-------------------------|---|
| (1) Changeover / Selector switch      | (7) Pressure regulator  | (13) CNG cylinder   |
| (2) CNG controller                    | (8) CNG filter          | (14) Low pressure CNG hose (chamber to rail)              |
| (3) Low pressure & temperature sensor | (9) High pressure pipe  | (15) Low pressure CNG hose (filter to chamber)            |
| (4) CNG injectors                     | (10) CNG cylinder valve | (16) Low pressure CNG hose (pressure regulator to filter) |
| (5) Water hose                        | (11) Vent hose          |   |
| (6) High pressure sensor              | (12) Receptacle         |   |

## FOR VEHICLES FITTED WITH CNG FUEL SYSTEM

### FUEL MODES

There are three fuel modes in the vehicle (Petrol, Auto and Forced CNG) which are selectable by pressing the selector switch (1) located on the right side of the steering wheel on the dashboard.

#### WARNING

Make sure that the parking brake is applied fully and the transmission is in Neutral before attempting to start the engine.

#### CAUTION

- Stop turning the starter immediately after the engine has started or the starter system can be damaged.
- Do not crank the engine for more than 15 seconds at a time. If the engine doesn't start on the first try, wait about 15 seconds before trying again.

#### NOTE:

- Do not press the accelerator pedal to change-over from petrol to CNG mode.
- With ignition switch "ON" and engine not running, blinking of CNG malfunction warning lamp indicates that CNG fuel filler valve cover is open. Vehicle will not start in this condition.

### SELECTOR SWITCH POSITION

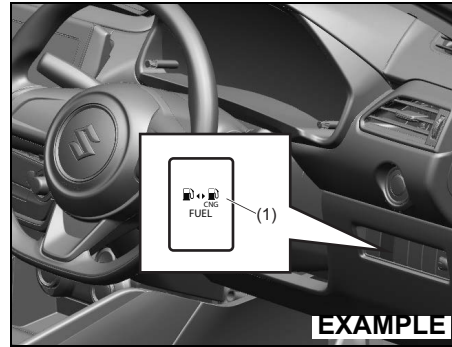

### PETROL MODE

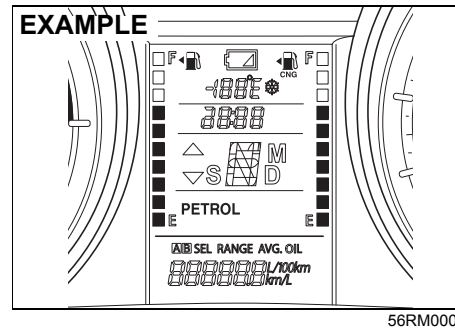

In this mode vehicle starts in petrol and continue running in petrol mode. In this mode, petrol indicator is continuously displayed and CNG indicator will remain "OFF".

played and CNG indicator will remain "OFF".

### AUTO MODE

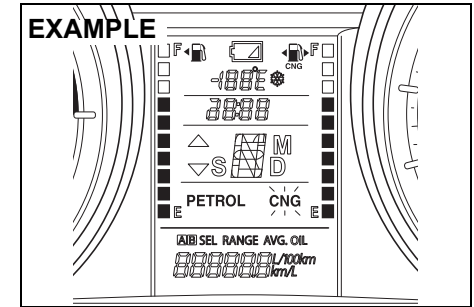

In this mode engine starts in petrol mode and then automatically changes to CNG after reaching programmed warming up condition. With ignition switch ON and vehicle started in "AUTO MODE", CNG indicator blinks on the display and PETROL indicator is displayed. After change-over to CNG, CNG indicator will be displayed and Petrol indicator will switch OFF automatically.

#### NOTE:

- It is always recommended to start the vehicle in AUTO MODE or PETROL MODE to enhance the engine life.
- The fuel changeover to CNG may not happen if the vehicle is started when the ambient / engine temperature is below

Zero Degree Celsius. In such a case, run the engine in PETROL MODE till it warms up and then try restarting the engine to changeover to CNG.

**FORCED CNG MODE**

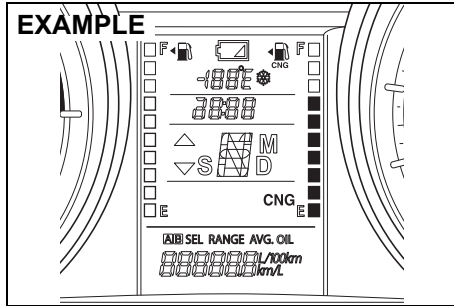

56RM0005

This is emergency mode and may be used in cases where there is no petrol in petrol tank. In this mode vehicle starts in CNG mode and continues running in CNG mode. With ignition "ON" and engine not running, press and hold the changeover switch till only CNG indicator is displayed. In this mode, CNG indicator is displayed and Petrol indicator remains "OFF".

**NOTE:**

- It is recommended to keep sufficient amount of petrol in the petrol tank.
- The vehicle may not start in Forced CNG mode if the ambient / engine temperature is below Zero Degree Celsius. It is

recommended to start the vehicle in Auto mode.

**AUTOMATIC CHANGEOVER FROM CNG MODE TO PETROL MODE**

If CNG is finished while the engine is running, vehicle will automatically changeover from CNG mode to Petrol mode & CNG malfunction warning lamp will start blinking. Petrol indicator will be displayed continuously and CNG indicator will switch OFF automatically.

To acknowledge this information, press the changeover switch once. The CNG malfunction warning lamp will stop blinking after the changeover switch is pressed and Petrol indicator will be displayed continuously. However the CNG malfunction indicator lamp will continue to blink after every subsequent Ignition ON - Ignition OFF condition until the vehicle is refilled with CNG.

**NOTE:**

- It is recommended to keep sufficient amount of petrol in the petrol tank to prevent engine stalling while automatic changeover from CNG mode to Petrol mode.
- In case the CNG malfunction warning lamp does not stop blinking after pressing the changeover switch, take the vehicle to the nearest MARUTI SUZUKI dealer.

**CNG LEVEL INDICATOR**

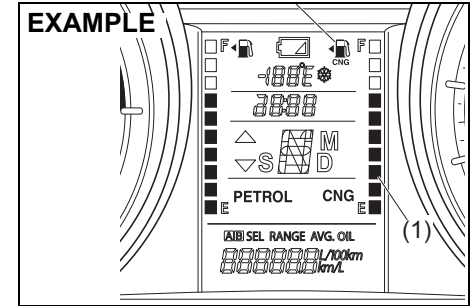

56RM0006

CNG level indicator (1) is built into the display. When the ignition switch is in the "ON" position, this gauge gives an approximate indication of the quantity of fuel in the fuel tank. "F" stands for full and "E" stands for empty.

If the CNG level meter indicator shows only one segment to "E" refill the CNG tank as soon as possible.

**NOTE:**

If the CNG low fuel warning light (3) comes on, fill the CNG tank immediately.

The mark (2) indicates that the fuel filler door is located on the left side of the vehicle.

## FOR VEHICLES FITTED WITH CNG FUEL SYSTEM

### CNG FILLER VALVE

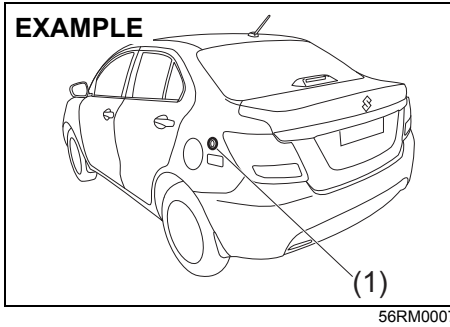

The CNG filler valve (1) is located on left outboard side of the vehicle, near the fuel (petrol) filler lid.

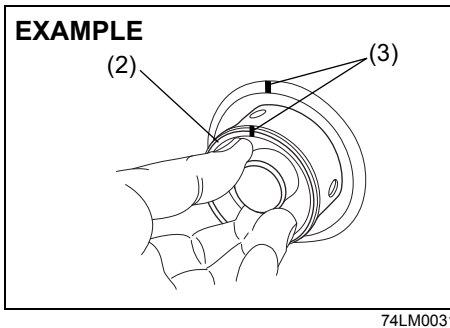

CNG filler valve (1) can be accessed by pulling out the filler valve cover (2) and can be closed by simply pushing it back.

CNG filling automatically gets cut off when the cylinder pressure becomes equal to dispenser pressure. After CNG filling, ensure that the filler valve cover (2) is closed.

**NOTE:**

- If the Fuel filler valve cover (2) is kept open, you will not be able to start the vehicle.
- Engine will stop if the fuel filler valve cover (2) is opened in vehicle stationary condition.
- For proper fitment of CNG filler valve cover (2), align the marking (3) on filler valve cover with the filler valve when pushing back the filler valve cover.

### CNG CYLINDER

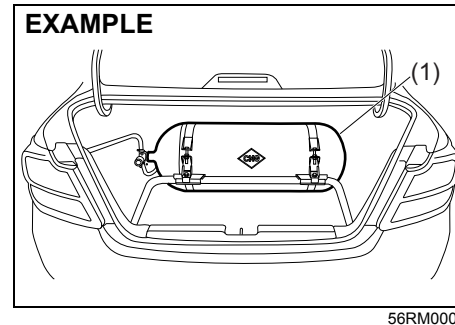

CNG cylinder (1) is installed in the luggage compartment.

**▲ CAUTION**

Do not place any luggage or load over cylinder as it may damage the cylinder, pipe, hose, valve etc.

### CNG CYLINDER WARNING LABEL

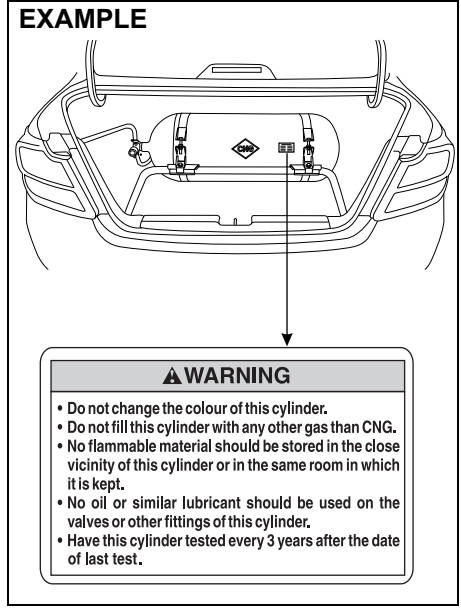

You may find this label on the CNG cylinder.



**MANUAL SHUT-OFF VALVE**

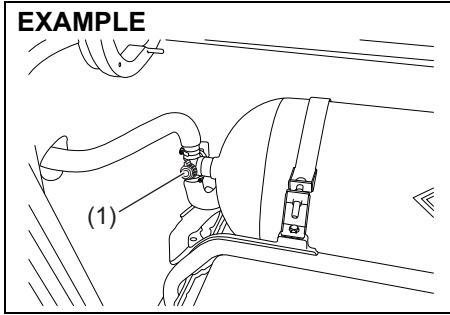

74LM0008

Manual shut-off valve (1) is located on the left hand side of the CNG cylinder.

**MANUAL SHUT-OFF VALVE OPERATION**

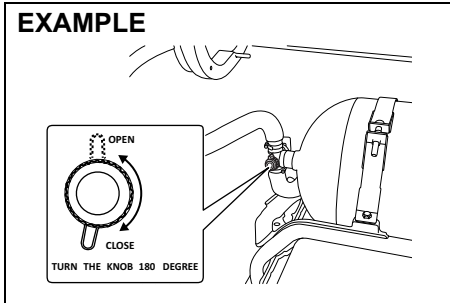

74LM0009

CNG supply can be switched off by closing the manual shut-off valve.

**Valve closing:** Turn the knob in clockwise direction to close the CNG supply to Engine.

**Valve opening:** Turn the knob in anti-clockwise direction to open the CNG supply to Engine.

**NOTE:**

- If the manual shut-off valve is not opened fully, then the engine may not run properly.
- If the manual shut-off valve is in closed condition, it is not possible to fill CNG into the cylinder.

**NOTE:**

- As per Government regulation, CNG cylinder needs to be checked and certified every three (3) years from the date of initial testing as mentioned on the CNG cylinder identification plate.
- Customer has to present the vehicle to a government approved testing agency.
- Failure to test the cylinder may result in denying of CNG filling by the CNG dispensing stations or may result in confiscating the vehicle by enforcement authorities.
- All the expenses for CNG cylinder testing has to be borne by the customer.
- As per Government regulation, CNG cylinder has to be discarded at 20 years from the date of initial testing as mentioned in the CNG cylinder identification plate.

- Customer has to discard the cylinder at his / her expense through government approved scrap agencies.
- No person shall refill any cylinder, which has been repaired under sub-rule (2) with any gas unless a full report on the repairs and test carried out on the cylinder, accompanied by the repairer's certificate of testing are furnished to the Chief Controller and his permission is obtained for its refilling.

**⚠ WARNING**

- **Never remove the cylinder valve from the cylinder assembly. For any assistance consult Maruti Suzuki authorized workshop.**
- **Never try to clean the cylinder. In case of any problem, contact Maruti Suzuki authorized workshop.**
- **Do not reuse the cylinder valve, once it is replaced / removed from cylinder assembly.**
- **Even if the CNG from the cylinder is consumed till engine stops, some amount of CNG will be left out in the tank under pressure.**

## FOR VEHICLES FITTED WITH CNG FUEL SYSTEM

### LIST OF GOVERNMENT APPROVED CNG CYLINDER TESTING STATIONS

To obtain testing stations information visit the following internet website address "www.peso.gov.in"

### SPARE WHEEL LOCATION

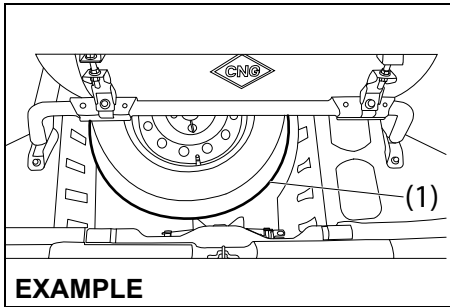

56RM0010

Spare wheel (1) is located in luggage compartment, placed below the luggage compartment carpet and secured with help of a mounting knob.

### JACK REMOVAL PROCEDURE

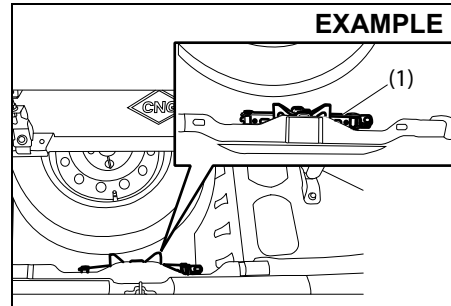

56RM0011

Jack (1) is located in the luggage compartment, below the luggage compartment board as shown in illustration.

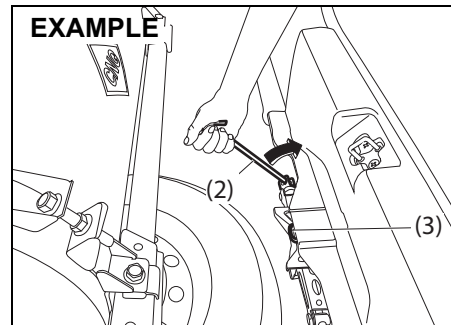

56RM0012

Remove the jack by rotating the jack shaft anti-clockwise by using jack handle (2) and pull the jack out of the storage bracket (3).

To stow the jack, place it in the storage bracket and turn the shaft clockwise until the jack is securely held in place.

#### NOTE:

*While stowing the jack ensure that the jack shaft is positioned facing toward rear of the vehicle.*

### SPARE WHEEL REMOVAL PROCEDURE

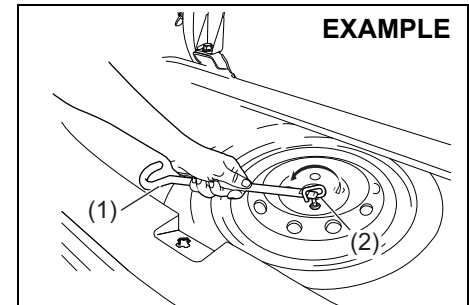

56RM0016

- Use jack handle (1) to dismount spare wheel.
- Place the jack handle (1) as shown above and rotate in anti-clockwise direction to unlock the mounting knob (2).

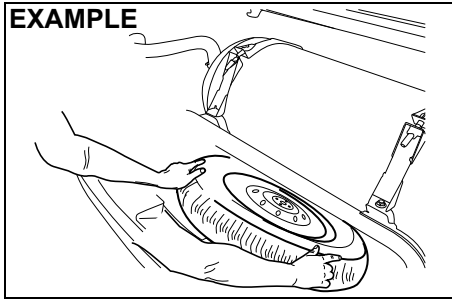

56RM0017

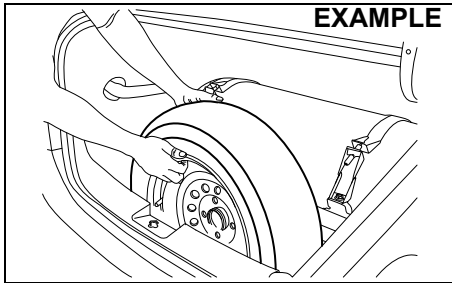

56RM0018

- (c) Take out the spare wheel by lifting the spare wheel in vertical direction as shown in above.
- (d) Reverse the above procedure for mounting the spare wheel in its position.

**NOTE:**

Make sure not to damage the trim while removing spare wheel.

**INSTRUMENT CLUSTER**

- 1) Tachometer
- 2) Speedometer
- 3) CNG low fuel warning light
- 4) CNG malfunction warning indicator lamp
- 5) Indicator selector knob
- 6) Fuel gauge (CNG)
- 7) Fuel gauge (Petrol)
- 8) Trip meter selector knob
- 9) Information display

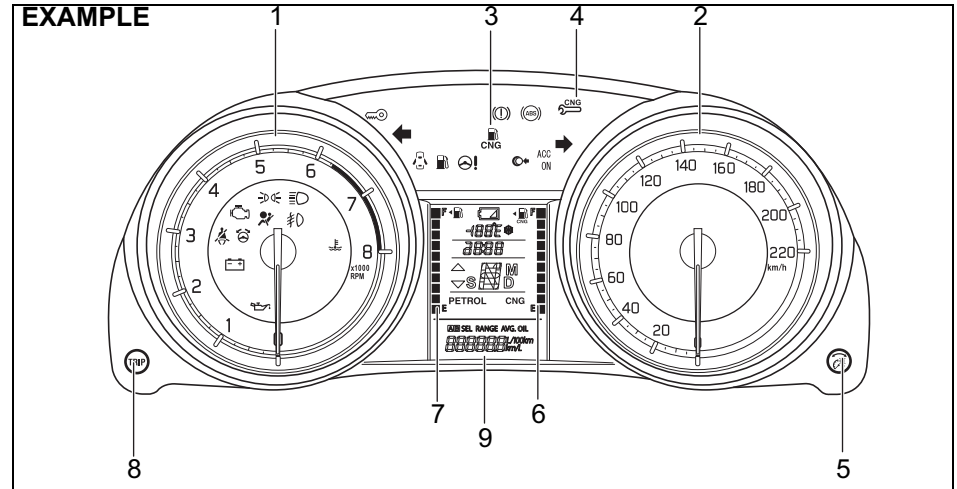

56RM0013

**NOTE:**

- When the engine is running on Auto mode or Forced CNG mode, Instantaneous fuel consumption, Average fuel consumption and Driving range information will not be displayed on information display (9).
- If CNG mode is changed to Petrol mode, Instantaneous fuel consumption will appear after few second, whereas Average fuel consumption and Driving range will appear immediately, depending on the display selected.

## FOR VEHICLES FITTED WITH CNG FUEL SYSTEM

### CNG MALFUNCTION WARNING LAMP

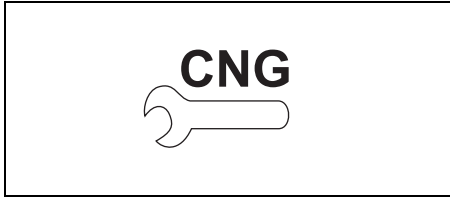

74LM0015

When the ignition switch is turned "ON", this CNG malfunction warning lamp comes on briefly, to check that the CNG malfunction lamp is trouble free.

- If CNG malfunction warning lamp glows continuously, with ignition "ON" there is some problem with the CNG system. Immediately get your vehicle checked by Maruti Suzuki authorized workshop.
- If CNG malfunction warning lamp blinks during engine running, it means there is some problem in CNG system in which vehicle cannot continue running in CNG-MODE and automatically switchover to petrol mode. Have your vehicle checked at Maruti Suzuki authorized workshop.

#### NOTE:

*With ignition switch "ON" and engine not running, blinking of CNG lamp indicates that CNG fuel filler valve cover is open. Vehicle will not start in this condition. Close the CNG Fuel filler valve cover in order to start the vehicle.*

### CNG LOW FUEL WARNING LIGHT



74LM0016

If this light comes on, fill the CNG tank immediately.

When this light comes on, a ding sounds once to remind you to fill the fuel.

If you do not fill the fuel, a ding sounds every time when the ignition switch is turned to "ON" position.

### CNG KIT IDENTIFICATION

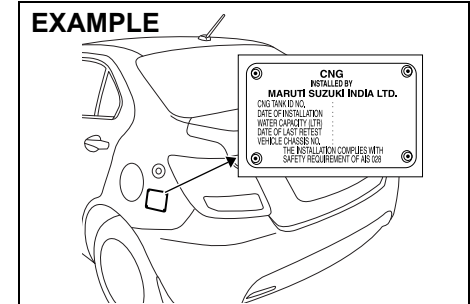

56RM0014

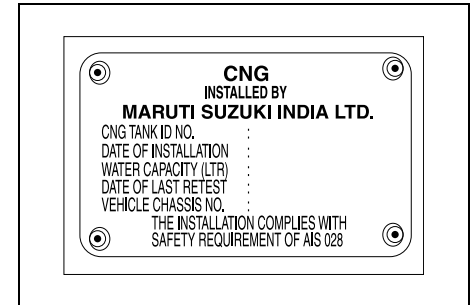

74LM0018

CNG cylinder identification number and CNG kit installation date is located near the CNG fuel filler valve.

**CNG WARNING LABEL**

Front Driver Door

**EXAMPLE**

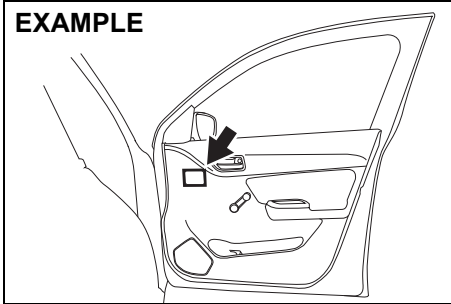

56RM0015

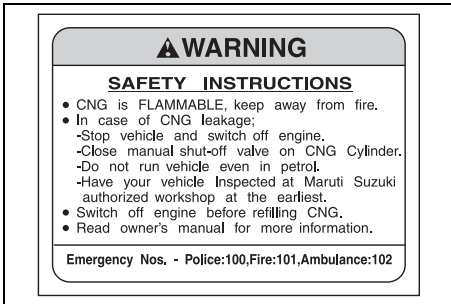

74LM0020

CNG warning label is located on front right door.

**FUSE BOX (Under Dashboard)**

Type A

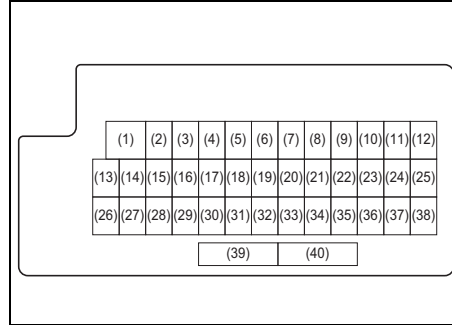

56RM07002

PRIMARY FUSE		
(1)	30 A	P/W (power window)
(2)	10 A	MTR (meter)
(3)	15A	IG (ignition coil)
(4)	5A	IG1 SIG2 (ignition-1 signal 2)
(5)	20 A	SHIFT (shift lever)
(6)	20A	S/R (sun roof) (if equipped)
(7)	-	Blank
(8)	20 A	D/L (door lock)
(9)	15 A	STL (steering lock)

(10)	10 A	HAZ (hazard warning light)
(11)	5A	A-STOP (auto stop)
(12)	10A	RR FOG (rear fog light)
(13)	5 A	ABS (anit-lock brake controller)
(14)	15A	R-A/C (rear air conditioner)
(15)	5A	CNG Ignition-1 signal
(16)	10 A	DOME2 (dome light-2)
(17)	5 A	DOME (dome light)
(18)	15 A	RADIO (radio)
(19)	5 A	CONT (gateway controller)
(20)	5 A	KEY 2 (key 2)
(21)	20 A	P/W T (power window timer)
(22)	5 A	KEY (key)
(23)	15 A	HORN (horn)
(24)	5 A	TAIL L (tail light (Left))
(25)	10 A	TAIL (tail light)
(26)	10 A	A/B (air bag)
(27)	10 A	IG1 SIG (ignition-1 signal)

## FOR VEHICLES FITTED WITH CNG FUEL SYSTEM

(28)	10 A	BACK (back up light)
(29)	5 A	ACC-3 (accessory-3)
(30)	20 A	RR DEF (rear defogger)
(31)	10A	MRR HTR (mirror heater) (if equipped)
(32)	15 A	ACC-2 (accessory-2)
(33)	5 A	ACC (accessory)
(34)	10 A	Wiper (rear wiper)
(35)	5 A	IG2 SIG (ignition-2 signal)
(36)	15 A	WASH (washer)
(37)	25 A	FR WIP (front wiper)
(38)	10 A	STOP (stop light)
(39)	–	Blank
(40)	25 A	RR DEF2 (rear defogger)

### Type B

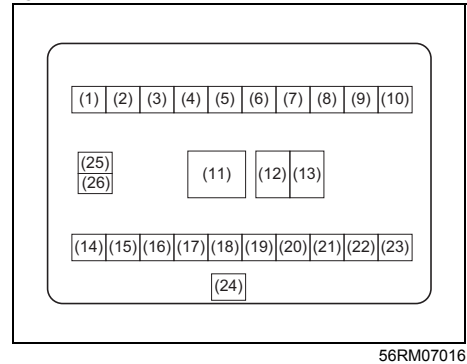

### PRIMARY FUSE

(1)	10 A	BACK (back-up light)
(2)	15 A	IG (ignition)
(3)	10 A	METER (meter)
(4)	5 A	CONT (gateway controller)
(5)	5 A	IG2 SIG (ignition-2 signal)
(6)	15 A	WASH (washer)
(7)	25 A	FR WIPER (front wiper)
(8)	10 A	TAIL (tail light)
(9)	10 A	HAZ (hazard warning light)

(10)	10 A	STOP (stop light)
(11)	30 A	P/W (power window)
(12)	15 A	ACC-2 (accessory-2)
(13)	5 A	ACC (accessory)
(14)	5 A	ST SIG (starting signal)
(15)	10 A	IG SIG (ignition signal)
(16)	10 A	A/B (air bag)
(17)	5 A	ABS/ESP (anti-lock brake controller)
(18)	15 A	HORN (horn)
(19)	20 A	D/L (door lock)
(20)	5 A	CNG Ignition-1 signal
(21)	15 A	RADIO (radio)
(22)	5 A	DOME (dome light)
(23)	10 A	DOME-2 (dome light-2)
(24)	10 A	WIPER (rear wiper)
(25)	–	Blank
(26)	25 A	RR DEF (rear defogger)

**FUSE BOX (Engine Compartment)**

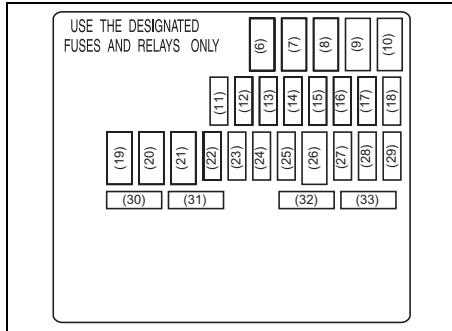

74LHM0704

(29) 7.5A - CNG VLV

(33) 7.5A - CNG

For other fuses, refer "Inspection and maintenance" section in the main owner's manual.

## FOR VEHICLES FITTED WITH CNG FUEL SYSTEM

### PERIODIC MAINTENANCE SCHEDULE

Kms (1 x 1000) Month	1	5	10	20	30	40	50	60	70	80	90	100
	1	6	12	24	36	48	60	72	84	96	108	120
All Joints (Gas leakage)	I	I	I	I	I	I	I	I	I	I	I	I
Coolant Hoses (Leakage, Damage)	I	I	I	I	I	I	I	I	I	I	I	I
All Fasteners Torque values	T	T	T	T	T	T	T	T	T	T	T	T
CNG low pressure filter cartridge with O-Ring	-	-	-	R	-	R	-	R	-	R	-	R
CNG cylinder leak testing and certification	Every 3 years from the date of initial testing by govt. approved testing agency											
CNG filler receptacle O-Ring	Replace every 4 years or 300,000 Km, whichever comes earlier											

T ..... Tighten to Specified Torque

I ..... Inspect and correct or replace if necessary

R ..... Replace

#### NOTE:

- *This table includes services as scheduled up to 100,000 km mileage. Beyond 100,000 km, carry out the same services at the same intervals respectively.*
- *For other maintenance details refer "Inspection & Maintenance" section in main Owner's Manual.*



**SPECIFICATIONS**

<b>Mass (Weight) (Kgs)</b>	
Kerb Weight	990 - 995 Kgs
Gross Weight	1405 Kgs
Seating Capacity	5 persons
<b>Fuel Capacity (litres)</b>	
Petrol	37 L
CNG (Water Filling Capacity	55 L

**NOTE:**

*Specifications are subject to change without notice.*

**NOTE:**

- 1) It is recommended to run the vehicle on petrol mode for 5~10 kms after every 300~500 km run in CNG mode to keep fuel system in good condition.*
- 2) Always keep minimum 5 litres of petrol in your petrol tank.*

## FOR VEHICLES FITTED WITH CNG FUEL SYSTEM

### FIRE EXTINGUISHER

#### Do's and Don'ts

##### EXAMPLE

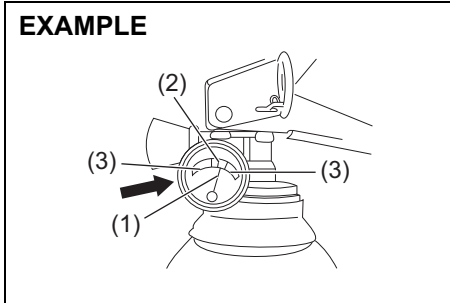

74LM0023

#### Do's

1. Check pressure gauge periodically. Max charging pressure is 15Kgf/cm<sup>2</sup> (in green zone (2)).
2. When pressure drops, indicator needle (1) will shift to the red zone (3). Immediately contact the fire extinguisher manufacturer as per the information provided on the fire extinguisher.
3. Get the fire extinguisher serviced only through the manufacturer service centre. Refer the information provided on the fire extinguisher to locate the nearest service centre.
4. Ensure that the Fire extinguisher is always kept at its prescribed position in the vehicle.
5. Refill the fire extinguisher immediately after use.

#### Don't

- Do not use water for cleaning fire extinguisher (Use clean cloth for removing dust).
- Do not rely on used or discharged fire extinguisher.

#### LOCATION

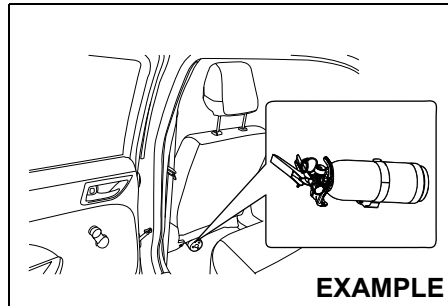

74LM0024

Fire extinguisher is located below co passenger's seat.

### PARTS DESCRIPTION

##### EXAMPLE

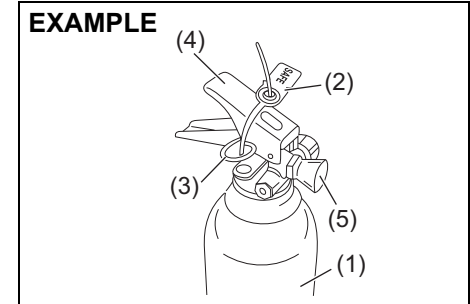

74LM0025

- (1) Fire extinguisher cylinder
- (2) Seal
- (3) Safety Pin
- (4) Lever
- (5) Nozzle

**REMOVAL PROCEDURE**

**Removing from front of co-passenger's seat:**

- 1) Pull up the co-passenger's seat position adjustment lever and slide the seat backward to the last position.
- 2) Lift Lever (1) of fire extinguisher slightly upwards and pull the fire extinguisher in the direction as shown in the figure, in order to disengage it from clamps (2).

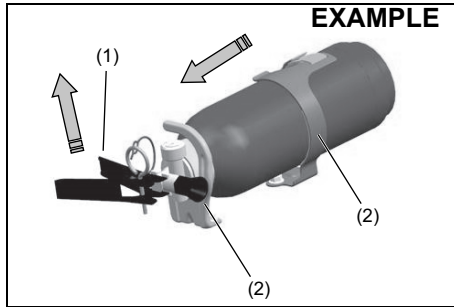

69RM0008

**Removing from back side of co-passenger's seat:**

- 1) Pull strap (3) in arrow direction as shown in figure to untie the clamp (2).

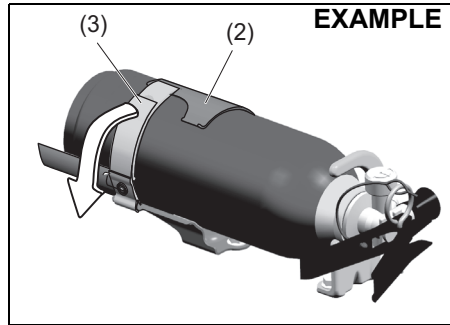

72RMC022

- 2) Remove the fire extinguisher from clamps (2) in the direction as shown in the figure.

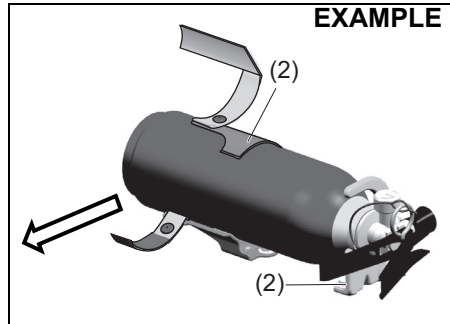

72RMC023

**PROCEDURE OF OPERATION**

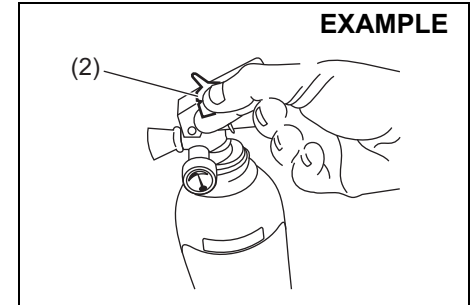

74LM0027

1. Hold the fire extinguisher (1) upright.
2. Break seal (2) by rotating the safety pin (3).

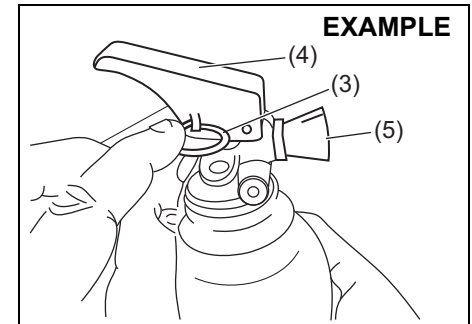

74LM0028

3. Pull Safety pin (3).
4. Squeeze lever (4) and direct the jet from nozzle (5) towards the near edge

## FOR VEHICLES FITTED WITH CNG FUEL SYSTEM

of the fire with a rapid (fast) sweeping motion.

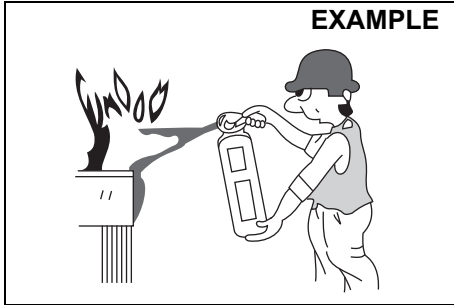

5. Drive the fire towards the far edge until flames are extinguished.

**NOTE:**

*Fire extinguisher is only meant for small fire caused in vehicle by external source only.*

### FITMENT PROCEDURE

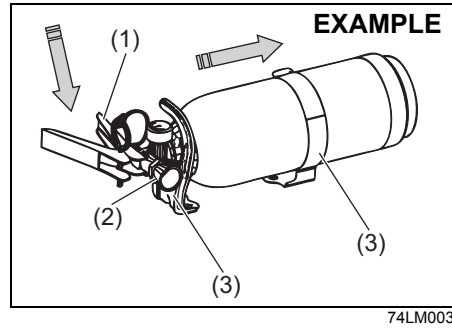

Insert the body of fire extinguisher (1) in to the clamps (3) and place the nozzle (2) carefully downwards, on the clamp.

**NOTE:**

*Ensure that the nozzle of fire extinguisher is properly seated on the clamp.*

### REFILLING SCHEDULES

1. Refilling is necessary after every use.
2. Fire extinguisher needs refilling after every 3 years even if it is not used.
3. Inspect every 6 months by the manufacturer authorised service center.



Prepared by

**MARUTI SUZUKI INDIA LIMITED**

Service Division

March, 2022

Part No. 99011M56RC0-74E

Printed in India

**For round-the-clock on-road assistance,  
call Maruti On-road Service at 1800 102 1800<sup>#</sup> / 1800 1800 180<sup>#</sup>**

*# No STD code to be prefixed.*

 **MARUTI SUZUKI**  
GENUINE ACCESSORIES

 **MARUTI SUZUKI**  
GENUINE PARTS

 **MARUTI SUZUKI**  
COST PROTECT

 **MARUTI SUZUKI**  
HELPLINE

 **MARUTI SUZUKI**  
ROAD SERVICE

SERVICE DIVISION

**MARUTI SUZUKI INDIA LIMITED**

Palam-Gurgaon Road, Gurgaon – 122 015 (Haryana), India

Visit us at: [www.marutisuzuki.com](http://www.marutisuzuki.com)



99011M56RC0-74E