

CONTENTS

INTRODUCTION TO CNG.....	1
SAFETY PRECAUTIONS (Do's)	1
SAFETY PRECAUTIONS (Don'ts)	1
LAYOUT OF THE CNG SYSTEM.....	2
FUEL MODES	3
CHANGEOVER / SELECTOR SWITCH POSITION	3
PETROL MODE.....	3
AUTO MODE	3
FORCED CNG MODE	4
CNG LEVEL INDICATOR	4
AUTOMATIC CHANGEOVER FROM CNG MODE TO PETROL MODE.....	4
CNG FILLER VALVE.....	5
CNG CYLINDER.....	5
CNG CYLINDER WARNING LABEL	5
MANUAL SHUT-OFF VALVE	6
MANUAL SHUT-OFF VALVE OPERATION.....	6
LIST OF GOVERNMENT APPROVED CNG CYLINDER TESTING STATIONS	7
SPARE TYRE REPLACEMENT	7
KIT IDENTIFICATION	8
CNG WARNING LABEL.....	9
INSTRUMENT CLUSTER	10
CNG MALFUNCTION WARNING LAMP	10
CNG LOW FUEL WARNING LIGHT	11
FUSES.....	11
PERIODIC MAINTENANCE SCHEDULE	13
SPECIFICATIONS.....	14
FIRE EXTINGUISHER	15

INTRODUCTION TO CNG:

CNG (Compressed Natural Gas) mainly contains methane. CNG is considered as a clean burning fuel. Due to low density of CNG, it is compressed at a pressure of around 200 bars to enhance the vehicle on-board storage capacity.

CAUTION

In case of any symptom of CNG leakage or releasing noise or any external damage to CNG piping or during accident, do not panic.

- **Stop the vehicle and switch off the engine, roll down the windows and open all the doors.**
- **Ensure to close manual shut off valve.**
- **Contact Maruti Suzuki authorised workshop immediately for further assistance.**

SAFETY PRECAUTIONS (Do's)

1. If any service or body repair is to be carried out, turn the manual shut off valve on CNG cylinder valve to close position prior to commencement of the repair work.
2. Get the CNG cylinder checked every three (3) years from the date of last testing / retesting of cylinder by government authorised CNG cylinder testing agency.
3. If the vehicle does not changeover to CNG in AUTO MODE, then have your vehicle checked by Maruti Suzuki authorised workshop at the earliest.
4. Switch "OFF" engine while filling the fuel (CNG/Petrol).
5. After refueling CNG or Petrol, ensure that the fuel filler lid is closed. (Otherwise vehicle cannot be started)
6. In AUTO MODE, the system is programmed to start the vehicle in petrol and automatically shift to CNG based on engine temperature & other parameters. Do not press the accelerator pedal to change from petrol to CNG.

SAFETY PRECAUTIONS (Don'ts):

1. Do not change/modify the configuration, settings or the components of CNG system.
2. The CNG cylinder should not be repaired under any circumstances. In case of any problem, consult with Maruti Suzuki authorised workshop.
3. Do not adjust setting of CNG system.
4. Never install LPG or any other gas cylinder in place of CNG cylinder.
5. Avoid carrying inflammable material near the CNG cylinder.
6. Do not fill any gas other than CNG.
7. Do not press the accelerator pedal to change from petrol to CNG MODE.

FOR VEHICLES FITTED WITH CNG FUEL SYSTEM

LAYOUT OF THE CNG SYSTEM

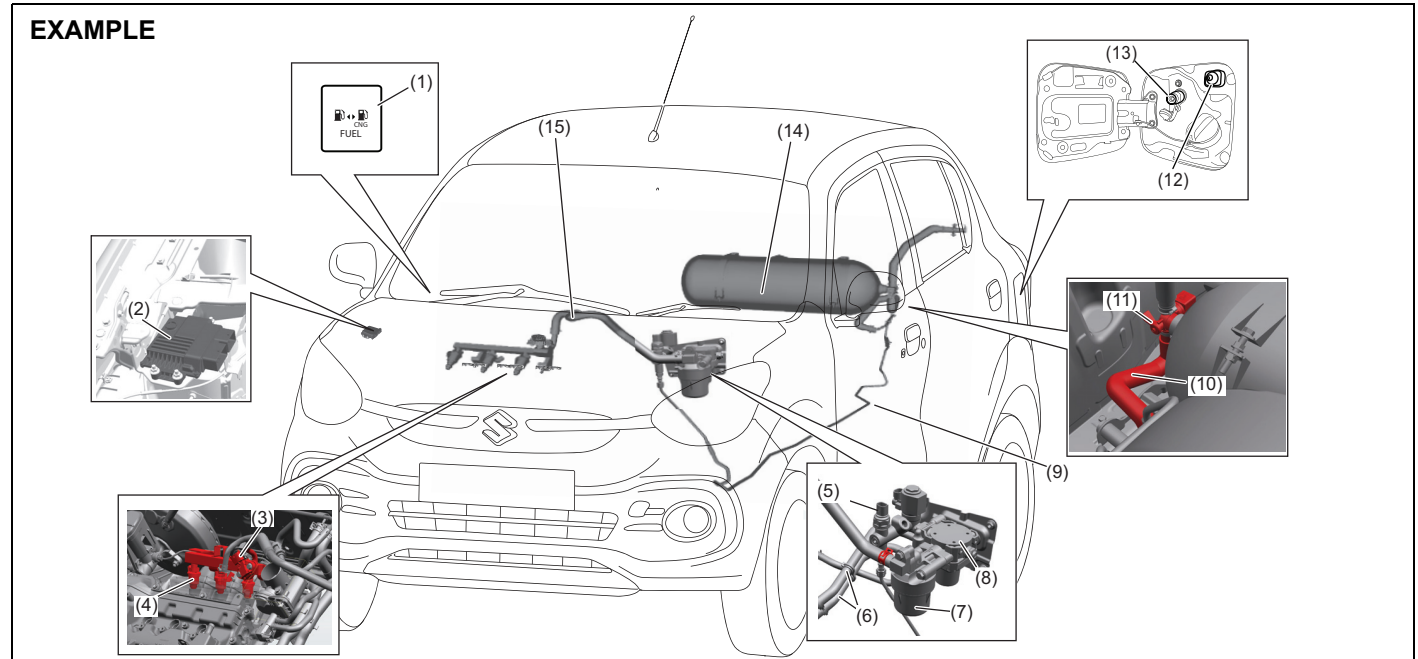

81RM0001

- | | | |
|---------------------------------------|-------------------------|---|
| (1) Changeover / Selector switch | (7) CNG filter | (13) CNG Receptacle / Filler valve |
| (2) CNG controller | (8) Pressure regulator | (14) CNG cylinder |
| (3) Low pressure & temperature sensor | (9) High pressure pipe | (15) Low pressure CNG hose (filter to rail) |
| (4) CNG injectors | (10) Vent hose | |
| (5) High pressure sensor | (11) CNG cylinder valve | |
| (6) Water hose | (12) Fuel lid switch | |

FUEL MODES

There are three fuel modes in the vehicle (Petrol, Auto and Forced CNG) which are selectable by pressing the changeover / selector switch (1) located on the right side of the steering wheel on the dashboard.

⚠ WARNING

Make sure that the parking brake is applied fully and the transmission is in Neutral before attempting to start the engine.

NOTICE

- For protection of a lead-acid battery and a starter motor, if you use the starter motor by turning the key to "START" for more than 12 seconds at a time, the starter motor stops automatically. Turn the key to "LOCK" position and wait for more than 30 seconds before trying again. If the engine does not start after several attempts, check the fuel and ignition system or consult a Maruti Suzuki authorised workshop.
- If the engine starts, the starter motor stops automatically.

NOTE:

- Do not press the accelerator pedal to changeover from petrol to CNG mode.

- With ignition switch "ON" and engine not running, blinking of CNG malfunction warning lamp indicates that fuel lid is open. Vehicle will not start in this condition. For details on CNG malfunction warning lamp, refer to "INSTRUMENT CLUSTER" section in this manual.

CHANGEOVER / SELECTOR SWITCH POSITION

EXAMPLE

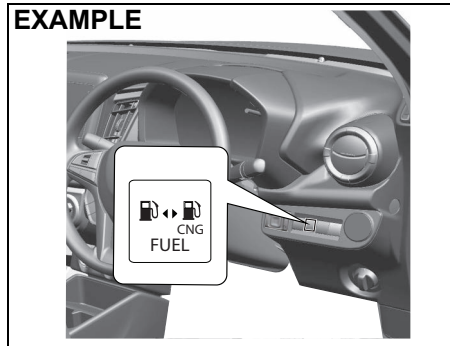

81RM0002

PETROL MODE

EXAMPLE

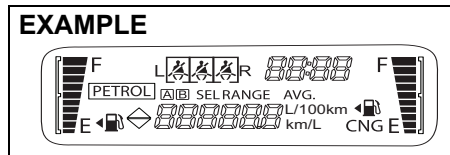

69RM0031

In this mode, vehicle starts in petrol and continues to run in petrol mode. In this

mode, PETROL indicator is continuously displayed and CNG indicator will remain "OFF".

AUTO MODE

EXAMPLE

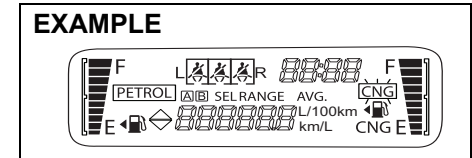

69RM0032

In this mode, engine starts in petrol mode and then automatically changes to CNG mode after reaching programmed warming up condition. With ignition switch ON and vehicle started in "AUTO MODE", CNG indicator blinks on the display and PETROL indicator is displayed. After changeover to CNG, CNG indicator will be displayed and PETROL indicator will switch OFF automatically.

NOTE:

- It is always recommended to start the vehicle in AUTO MODE or PETROL MODE to enhance the engine life.
- The fuel changeover to CNG may not happen if the vehicle is started when the ambient / engine temperature is below Zero Degree Celsius. In such a case, run the engine in PETROL MODE till it warms up and then try restarting the engine to changeover to CNG.

FOR VEHICLES FITTED WITH CNG FUEL SYSTEM

FORCED CNG MODE

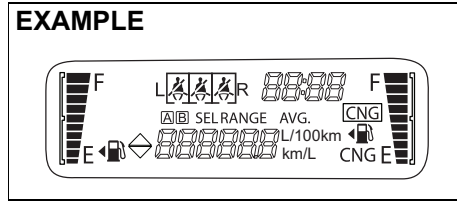

This is an emergency mode and may be used in cases where there is no petrol in the petrol tank. In this mode, vehicle starts in CNG mode and continues running in CNG mode. With ignition "ON" and engine not running, press and hold the changeover switch till only CNG indicator is displayed. In this mode, CNG indicator is displayed and PETROL indicator remains "OFF".

NOTE:

- It is recommended to keep sufficient amount of petrol in the petrol tank.
- The vehicle may not start in Forced CNG mode if the ambient / engine temperature is below Zero Degree Celsius. It is recommended to start the vehicle in Auto mode.

CNG LEVEL INDICATOR

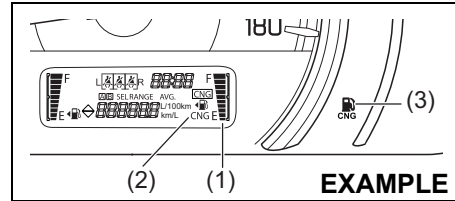

CNG level indicator (1) is built into the display. When the ignition switch is in the "ON" position, this gauge gives an approximate indication of the quantity of CNG fuel in the CNG tank. "F" stands for full and "E" stands for empty.

If the CNG level indicator shows only one segment to "E", refill the CNG tank as soon as possible.

NOTE:

If the last segment blinks, it means that the fuel is almost empty.
If the CNG low fuel warning light (3) comes on, fill the CNG tank immediately.

The mark (2) indicates that the fuel filler door is located on the left side of the vehicle.

AUTOMATIC CHANGEOVER FROM CNG MODE TO PETROL MODE

If CNG is finished while the engine is running, vehicle will automatically changeover from CNG mode to Petrol mode and CNG malfunction warning lamp will start blinking. PETROL indicator will be displayed continuously and CNG indicator will switch OFF automatically.

To acknowledge this information, press the changeover switch once. The CNG malfunction warning lamp will stop blinking after the changeover switch is pressed and PETROL indicator will be displayed continuously. However the CNG malfunction indicator lamp will continue to blink after every subsequent Ignition ON - Ignition OFF condition until the vehicle is refilled with CNG.

NOTE:

- It is recommended to keep sufficient amount of petrol in the petrol tank to prevent engine stalling while automatic changeover from CNG mode to Petrol mode.
- In case the CNG malfunction warning lamp does not stop blinking after pressing the changeover switch, take the vehicle to the nearest Maruti Suzuki authorised workshop.

CNG FILLER VALVE

EXAMPLE

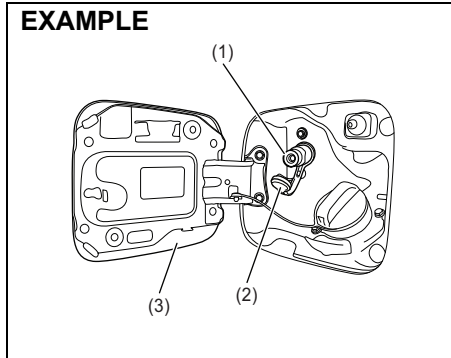

69RM0011

The CNG filler valve is integrated in fuel box next to petrol fuel filler cap.

CNG filler valve (1) can be uncovered by pulling out the filler valve cover (2) and it can be covered by simply pushing it back.

Filling automatically gets cut off when the cylinder pressure becomes equal to dispenser pressure. After CNG filling, ensure that the filler valve cover (2) and fuel filler lid (3) is closed.

NOTE:

- If the fuel filler lid (3) is kept open, you will not be able to start the vehicle.
- Engine will stop if the fuel filler lid (3) is opened in vehicle stationary condition.

CNG CYLINDER

EXAMPLE

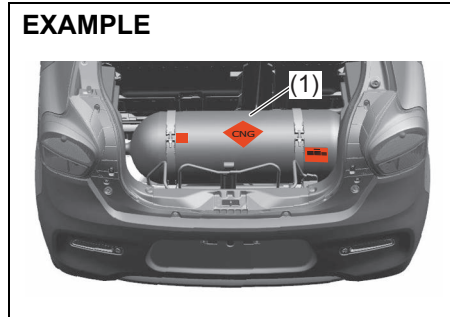

81RM0019

CNG cylinder (1) is installed in the luggage compartment.

⚠ CAUTION

Do not place any luggage or load over cylinder as it may damage the cylinder, pipe, hose, valve etc.

CNG CYLINDER WARNING LABEL

EXAMPLE

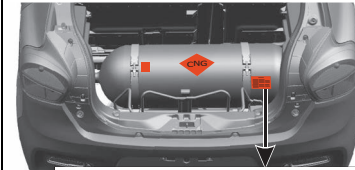

⚠ WARNING

- Do not change the colour of this cylinder.
- Do not fill this cylinder with any other gas than CNG.
- No flammable material should be stored in the close vicinity of this cylinder or in the same room in which it is kept.
- No oil or similar lubricant should be used on the valves or other fittings of this cylinder.
- Have this cylinder tested every 3 years after the date of last test.

81RM0020

You may find this label on the CNG cylinder.

FOR VEHICLES FITTED WITH CNG FUEL SYSTEM

MANUAL SHUT-OFF VALVE

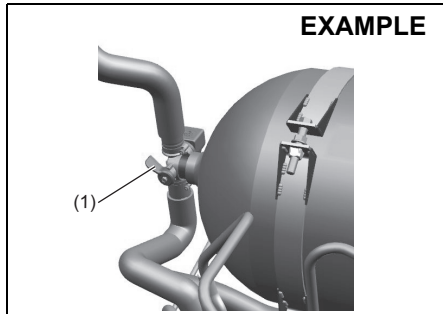

Manual shut-off valve (1) is located on the left hand side of the CNG cylinder.

MANUAL SHUT-OFF VALVE OPERATION

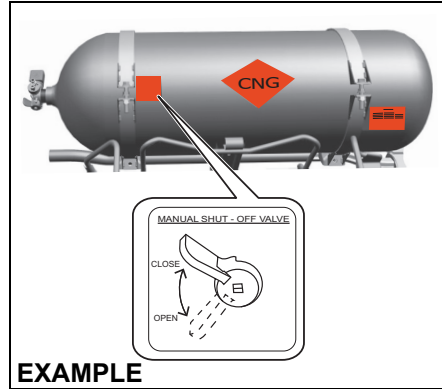
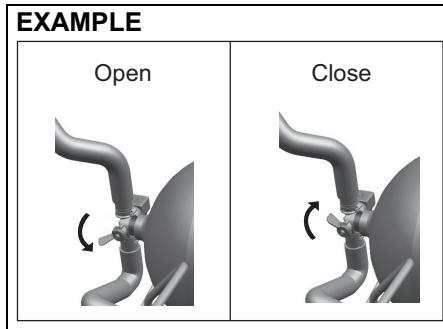

CNG supply can be switched off by closing the manual shut-off valve.

Valve closing: Turn the knob completely in clockwise direction to close the CNG supply to engine.

Valve opening: Turn the knob completely in anticlockwise direction to open the CNG supply to engine.

NOTE:

- If the manual shut-off valve is not opened fully, then the engine may not run properly.
- If the manual shut-off valve is in closed condition, it is not possible to fill CNG into the cylinder.

NOTE:

- As per Government regulation, CNG cylinder needs to be checked and certified every 3 years from the date of initial testing as mentioned on the CNG cylinder identification plate.
For details on CNG cylinder identification plate, refer to "KIT IDENTIFICATION" section in this manual.
- Customer has to present the vehicle to a government approved testing agency.
- Failure to test the cylinder may result in denying of CNG filling by the CNG dispensing stations or may result in confiscation of the vehicle by enforcement authorities.
- All the expenses for CNG cylinder testing has to be borne by the customer.
- As per Government regulation, CNG cylinder has to be discarded at 20 years from the date of initial testing as mentioned in the CNG cylinder identification plate.
- Customer has to discard the cylinder at his / her expense through government approved scrap agencies.
- No person shall refill any cylinder, which has been repaired under sub-rule (2) with any gas unless a full report on the repairs and test carried out on the cylinder, accompanied by the repairer's certificate of testing are furnished to the Chief Controller and his permission is obtained for its refilling.

⚠ WARNING

- Never remove the cylinder valve from the cylinder assembly. For any assistance, consult Maruti Suzuki authorised workshop.
- Never try to clean the cylinder. In case of any problem, contact Maruti Suzuki authorised workshop.
- Do not reuse the cylinder valve, once it is replaced / removed from cylinder assembly.
- Even if the CNG from the cylinder is consumed till engine stops, some amount of CNG will be left out in the tank under pressure.

LIST OF GOVERNMENT APPROVED CNG CYLINDER TESTING STATIONS

To obtain testing stations information, visit the following internet website address "www.peso.gov.in".

SPARE TYRE REPLACEMENT

EXAMPLE

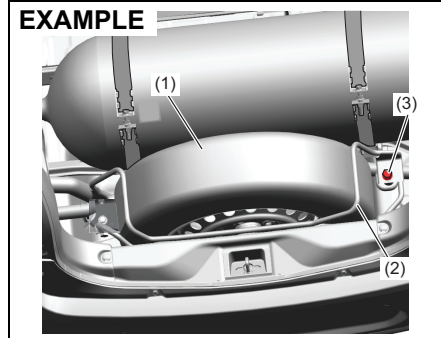

81RM0010

EXAMPLE

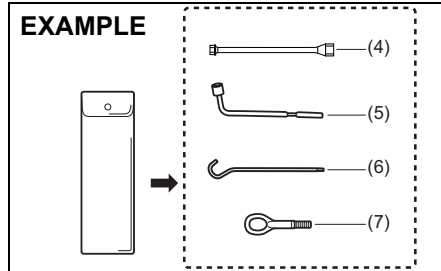

69RM0021

- (1) Spare tyre
- (2) Carrier
- (3) Carrier bolt
- (4) Extension
- (5) Wheel brace
- (6) Jack handle
- (7) Towing hook

- 1) For removal of spare tyre, place extension (4) on spare tyre carrier bolt (3) and wheel brace (5) over extension head. Rotate the wheel brace in anti-clockwise direction to loosen the carrier bolt.

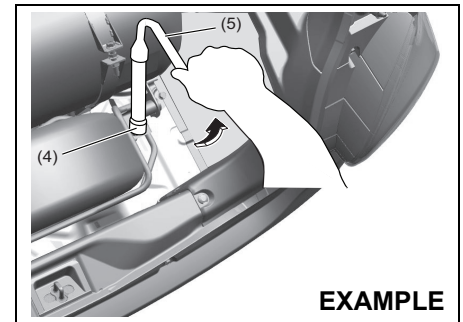

EXAMPLE

81RM0009

- 2) Use the flat end of wheel brace to fully open carrier bolt.

FOR VEHICLES FITTED WITH CNG FUEL SYSTEM

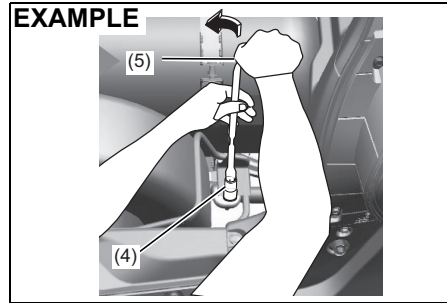

81M0011

- 3) Remove extension and carrier bolt. Open the carrier and take out the spare tyre.
- 4) For installing spare tyre, follow the reverse order of removal.

NOTE:

Ensure that air filling nozzle (8) is facing towards rear of the vehicle while placing the tyre inside the carrier.

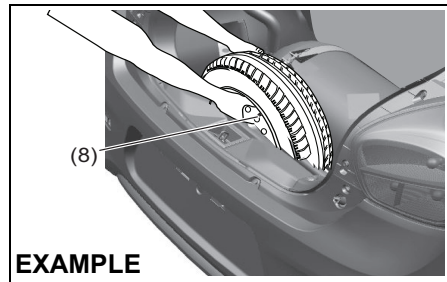

81RM0012

- 5) Verify that the spare tyre is stored securely. The bolt should be tightened till the bracket of the carrier (2) touches the spacer (9).

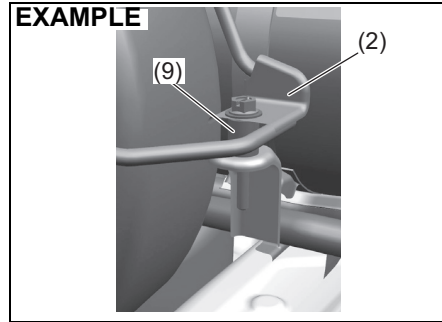

53MHMC012

KIT IDENTIFICATION

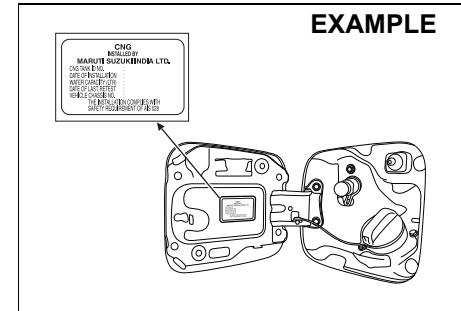

81RM0017

CNG cylinder identification number and CNG kit installation date is mentioned on the CNG cylinder identification plate located inside fuel filler lid.

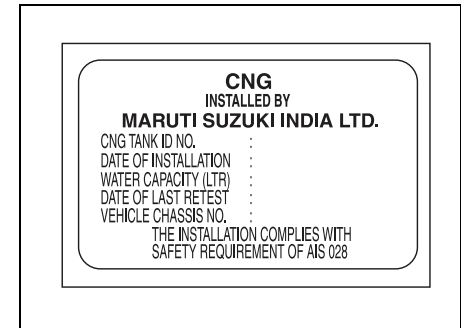

53MHMC017

CNG WARNING LABEL

Front Driver Door

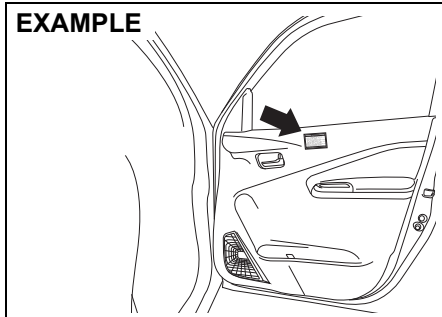

81RM0016

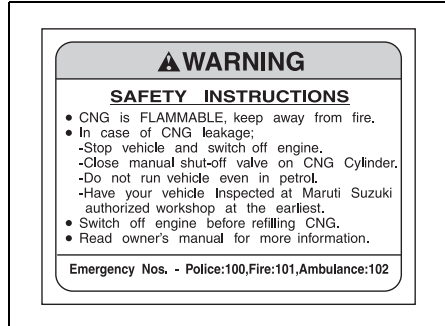

53MHMC019

CNG warning label is located on front right door.

FOR VEHICLES FITTED WITH CNG FUEL SYSTEM

INSTRUMENT CLUSTER

- | | |
|--|--------------------------------|
| (1) Speedometer | (5) CNG low fuel warning light |
| (2) Other warning and indicator lamps | (6) Fuel indicator (CNG) |
| (3) Odometer / Tripmeter selector knob | (7) Odometer / Tripmeter |
| (4) CNG malfunction warning Indicator lamp | (8) Fuel indicator (Petrol) |

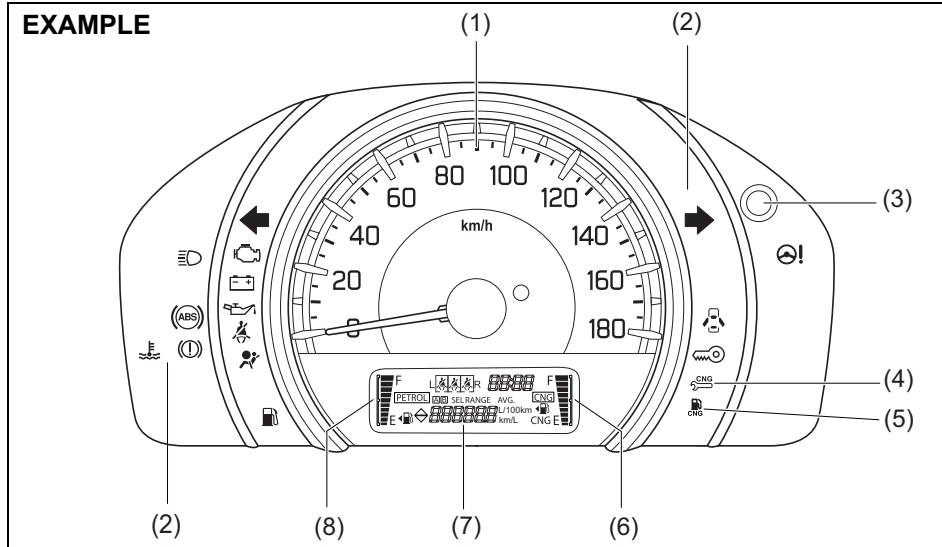

CNG MALFUNCTION WARNING INDICATOR LAMP



53MHMC015

When the ignition switch is turned "ON", this CNG malfunction warning lamp comes on briefly, to check that the CNG malfunction lamp is trouble free.

- If CNG malfunction warning lamp glows continuously, with ignition "ON" there is some problem with the CNG system. Immediately get your vehicle checked by Maruti Suzuki authorised workshop.
- If CNG malfunction warning lamp blinks during engine running, it means there is some problem in CNG system in which vehicle cannot continue running in CNG-MODE and automatically switches over to petrol mode. Have your vehicle checked at a Maruti Suzuki authorised workshop.

NOTE:

With ignition switch "ON" and engine not running, blinking of CNG lamp indicates that fuel lid is open. Vehicle will not start in this condition. Close the lid in order to start the vehicle.

CNG LOW FUEL WARNING LIGHT



69RM0028

If this light comes on, fill the CNG tank immediately.
 When this light comes on, a ding sounds once to remind you to fill the fuel.
 If you do not fill the fuel, a ding sounds every time when the ignition switch is turned to "ON" position.

FUSES

Fuses in engine compartment

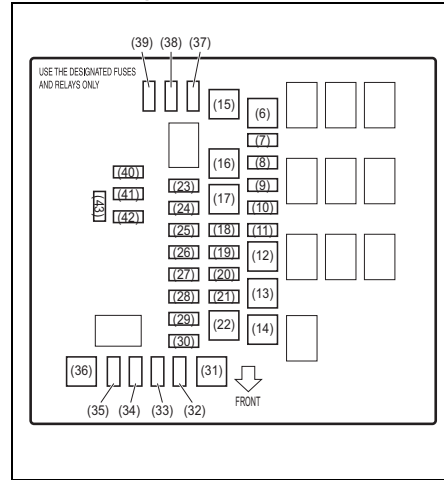

69RH194

(7)	7.5A	CNG valve
(25)	7.5A	CNG
(43)	7.5A	Spare

For other fuses, refer to "Inspection and maintenance" section in the main owner's manual.

Fuses under dashboard

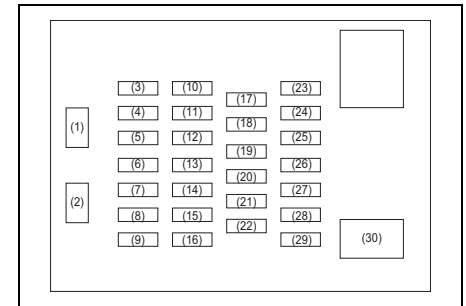

81RM06009

(1)	-	Blank
(2)	-	Blank
(3)	-	Blank
(4)	-	Blank
(5)	-	Blank
(6)	-	Blank
(7)	5A	Dome light
(8)	15A	Radio
(9)	5A	ST SIG (starting signal)
(10)	5A	CNG Ignition-1 signal
(11)	5A	Controller
(12)	15A	Horn
(13)	20A	Door Lock

FOR VEHICLES FITTED WITH CNG FUEL SYSTEM

(14)	5A	ACC
(15)	15A	ACC-2
(16)	5A	ACC-3
(17)	10A	Back-up light
(18)	10A	Airbag
(19)	10A	Ignition-1 signal
(20)	10A	Meter
(21)	5A	ABS control module
(22)	15A	Ignition coil
(23)	10A	Dome light-2
(24)	10A	Tail light
(25)	10A	Hazard
(26)	10A	STOP (stop light)
(27)	25A	Front wiper
(28)	5A	Ignition-2 signal
(29)	15A	Washer
(30)	30A	Power window

FOR VEHICLES FITTED WITH CNG FUEL SYSTEM

PERIODIC MAINTENANCE SCHEDULE

Kms (1 x 1000) Month	1	5	10	20	30	40	50	60	70	80	90	100
	1	6	12	24	36	48	60	72	84	96	108	120
Valve clearance	-	-	-	I	-	I	-	I	-	I	-	I
All Joints (Gas leakage)	I	I	I	I	I	I	I	I	I	I	I	I
Coolant Hoses (Leakage, Damage)	I	I	I	I	I	I	I	I	I	I	I	I
All Fasteners Torque values	T	T	T	T	T	T	T	T	T	T	T	T
CNG low pressure filter cartridge with O-Ring	-	-	-	R	-	R	-	R	-	R	-	R
CNG cylinder leak testing and certification	Every 3 years from the date of initial testing by govt. approved testing agency											
CNG filler receptacle O-Ring	Replace every 4 years or 300,000 Km, whichever comes earlier											

TTighten to Specified Torque

I Inspect and correct or replace if necessary

R Replace

NOTE:

- This table includes services as scheduled up to 100,000 km mileage. Beyond 100,000 km, carry out the same services at the same intervals respectively.
- For other maintenance details, refer to "Inspection & Maintenance" section in main Owner's Manual

FOR VEHICLES FITTED WITH CNG FUEL SYSTEM

SPECIFICATIONS

Mass (Weight) (Kg)	
Kerb Weight	915 Kg
Gross Weight	1320 Kg
Seating Capacity	5 persons
Fuel Capacity (litre)	
Petrol	32 L
CNG (Water Filling Capacity)	60 L

NOTE:

Specifications are subject to change without notice.

NOTE:

- 1) It is recommended to run the vehicle on petrol mode for 5~10 km after every 300~500 km run in CNG mode to keep fuel system in good condition.*
- 2) Always keep minimum 5 litre of petrol in your petrol tank.*

FIRE EXTINGUISHER

Do's and Don'ts

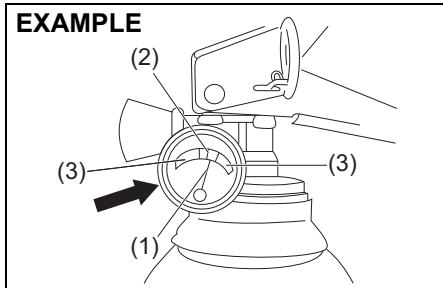

Do's

- Check pressure gauge periodically. Max charging pressure is 15Kgf/cm² (in green zone (2)).
- When pressure drops, indicator needle (1) will shift to the red zone (3). Immediately contact the fire extinguisher manufacturer as per the information provided on the fire extinguisher.
- Get the fire extinguisher serviced only through the manufacturer service centre. Refer the information provided on the fire extinguisher to locate the nearest service centre.
- Ensure that the Fire extinguisher is always kept at its prescribed position in the vehicle.
- Refill the fire extinguisher immediately after use.

Don't

- Do not use water for cleaning fire extinguisher. (Use clean cloth for removing dust)
- Do not rely on used or discharged fire extinguisher.

Location

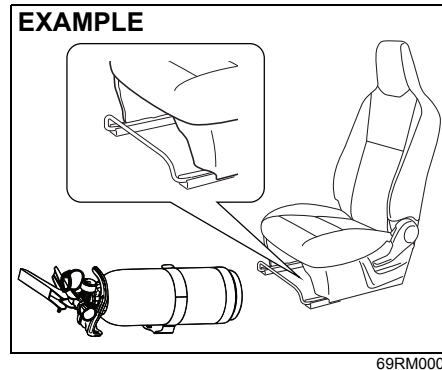

Fire extinguisher is located below front passenger's seat.

Parts Description

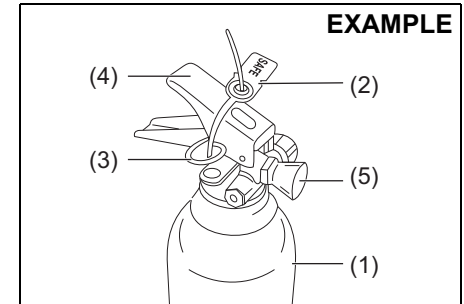

53MHMC024

- (1) Fire extinguisher cylinder
- (2) Seal
- (3) Safety Pin
- (4) Lever
- (5) Nozzle

FOR VEHICLES FITTED WITH CNG FUEL SYSTEM

Removal Procedure

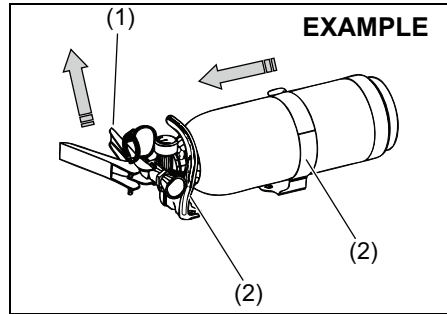

Lift the lever (1) of fire extinguisher slightly upwards and pull the fire extinguisher in the direction as shown in the figure, in order to disengage it from clamps (2).

Procedure of Operation

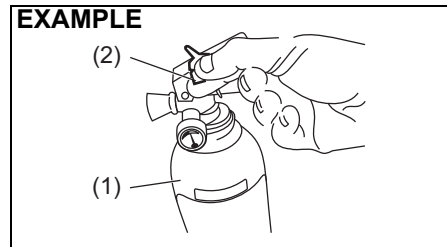

1. Hold the fire extinguisher (1) upright.
2. Break seal (2) by rotating the safety pin (3).

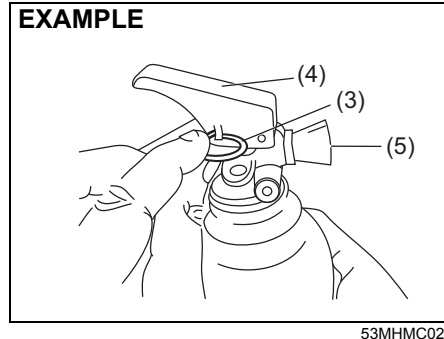

3. Pull Safety pin (3).
4. Squeeze lever (4) and direct the jet from nozzle (5) towards the near edge of the fire with a rapid (fast) sweeping motion.

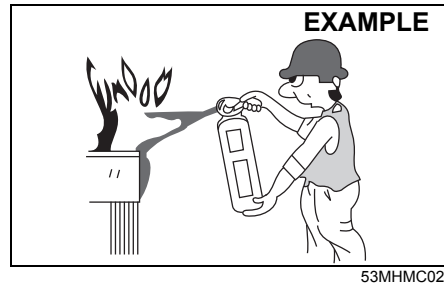

5. Drive the fire towards the far edge until flames are extinguished.

NOTE:

Fire extinguisher is only meant for small fire caused in vehicle by external source only.

Fitment Procedure

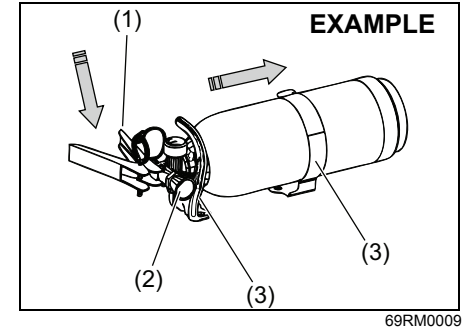

Insert the body of fire extinguisher (1) into the clamps (3) and place the nozzle (2) carefully downwards, on the clamp.

⚠ WARNING

Ensure that fire extinguisher is securely fixed into both the clamps. Otherwise, it may come from the clamps inadvertently that may cause injury.

NOTE:

Ensure that the nozzle of fire extinguisher is properly seated on the clamp.

Refilling Schedules

1. Refilling is necessary after every use.
2. Fire extinguisher needs refilling after every 3 years even if it is not used.
3. Get the fire extinguisher inspected every 6 months through the authorised service center of fire extinguisher manufacturer.