



B R E Z Z A

**SUPPLEMENTARY OWNER'S MANUAL
FOR VEHICLE FITTED WITH CNG FUEL SYSTEM**

Use this Supplementary Owner's manual along
with Owner's manual

Refer for vehicle usage at all times.

Contains important information on Safety, Operation & Maintenance.

Part No. 99011M66TC1-74W
February, 2025 (ENG.)

NOTE:

- **As per Government regulation, CNG cylinder needs to be checked and certified every THREE (3) YEARS from the date of initial testing as mentioned on the CNG cylinder identification plate. Customer has to present the vehicle to a government approved testing agency.**
- **As per Government regulation, CNG cylinder has to be discarded at 20 YEARS from the date of initial testing as mentioned in the CNG cylinder identification plate. Customer has to discard the cylinder at his / her expense through government approved scrap agencies.**
- **DO NOT reuse the cylinder valve, once it is replaced / removed from cylinder assembly.**

CONTENTS

INTRODUCTION TO CNG.....	1
SAFETY PRECAUTIONS (Do's and Don'ts)	1
LAYOUT OF THE CNG SYSTEM.....	2
FUEL MODES	3
SELECTOR SWITCH POSITION	3
PETROL MODE.....	3
AUTO MODE	4
FORCED CNG MODE	5
CNG LEVEL INDICATOR	5
AUTOMATIC CHANGEOVER FROM CNG MODE TO PETROL MODE.....	6
CNG FILLER VALVE.....	6
CNG CYLINDER.....	7
CNG CYLINDER WARNING LABEL	7
MANUAL SHUT-OFF VALVE	7
MANUAL SHUT-OFF VALVE OPERATION	7
LIST OF GOVERNMENT APPROVED CNG	
CYLINDER TESTING STATIONS	8
SPARE TYRE REPLACEMENT	9
KIT IDENTIFICATION	10
CNG WARNING LABEL.....	10
LUGGAGE COMPARTMENT HOOK.....	10
INSTRUMENT CLUSTER	11
CNG MALFUNCTION WARNING LAMP	13
CNG INFORMATION DISPLAY.....	13
CNG LOW FUEL WARNING LIGHT	14
FUSES.....	14
PERIODIC MAINTENANCE SCHEDULE	16
SPECIFICATIONS.....	17
FIRE EXTINGUISHER.....	18

INTRODUCTION TO CNG:

CNG (Compressed Natural Gas) mainly contains methane. CNG is considered as a clean burning fuel. Due to low density of CNG, it is compressed at a pressure of around 200 bars to enhance the vehicle on-board storage capacity.

CAUTION

In case of any symptom of CNG leakage or releasing noise or any external damage to CNG piping or during accident, do not panic.

- **Stop the vehicle and switch off the engine, roll down the windows and open all the doors**
- **Ensure to close manual shut off valve.**
- **Contact Maruti Suzuki authorised workshop immediately for further assistance.**

SAFETY PRECAUTIONS (Do's)

1. If any service or body repair is to be carried out, turn the manual shut off valve on CNG cylinder valve to close position prior to commencement of the repair work.
2. Get the CNG cylinder checked every three (3) years from the date of last testing / retesting of cylinder by government authorised CNG cylinder testing agency.
3. If the vehicle does not changeover to CNG in AUTO MODE, then have your vehicle checked by Maruti Suzuki authorised workshop at the earliest.
4. Switch "OFF" engine while filling the fuel (CNG/Petrol).
5. After refueling CNG or Petrol, ensure that the fuel filler lid is closed. (Otherwise vehicle cannot be started)
6. In AUTO MODE, the system is programmed to start the vehicle in petrol and automatically shift to CNG based on engine temperature & other parameters. Do not press the accelerator pedal to change from petrol to CNG mode.

SAFETY PRECAUTIONS (Don'ts):

1. Do not change/modify the configuration, settings or the components of CNG system.
2. The CNG cylinder should not be repaired under any circumstances. In case of any problem, consult with Maruti Suzuki authorised workshop.
3. Do not adjust setting of CNG system.
4. Never install LPG or any other gas cylinder in place of CNG cylinder.
5. Avoid carrying inflammable material near the CNG cylinder.
6. Do not fill any gas other than CNG.
7. Do not press the accelerator pedal to change from petrol to CNG MODE.

FOR VEHICLES FITTED WITH CNG FUEL SYSTEM

LAYOUT OF THE CNG SYSTEM

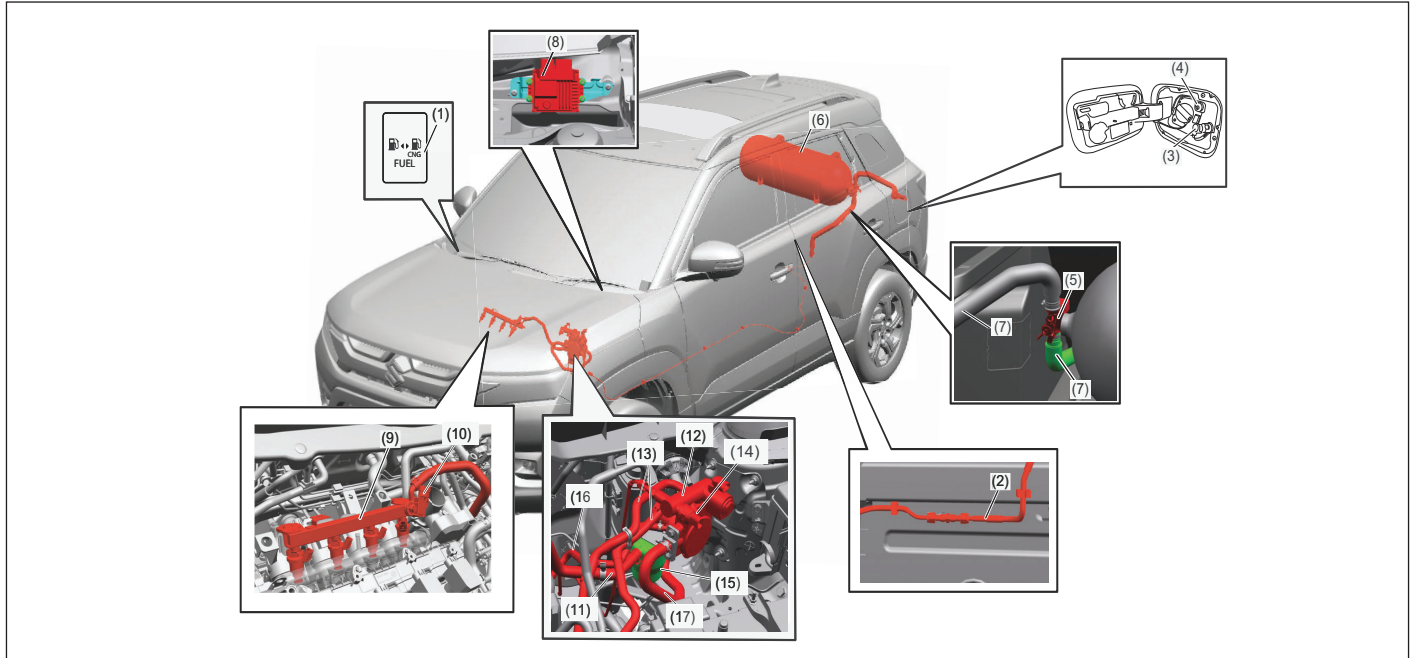

- (1) Changeover / Selector switch
- (2) High pressure pipe
- (3) CNG Receptacle / Filler valve
- (4) Fuel lid switch
- (5) CNG cylinder valve
- (6) CNG cylinder
- (7) Vent hose

- (8) CNG controller
- (9) CNG injectors
- (10) Low pressure & temperature sensor
- (11) Low pressure CNG hose (filter to rail)
- (12) Pressure regulator
- (13) Water hoses

- (14) High pressure sensor
- (15) CNG filter
- (16) CNG Vacuum hose
- (17) Low pressure CNG hose (Regulator to filter)

66TMC001

FUEL MODES

There are three fuel modes in the vehicle (Petrol, Auto and Forced CNG) which are selectable by pressing the changeover / selector switch (1) located on the right side of the steering wheel on the dashboard.

⚠ WARNING

Make sure that the parking brake is applied fully and the transmission is in Neutral before attempting to start the engine.

NOTICE

- For protection of a lead-acid battery and a starter motor, if you use the starter motor by turning the key to "START" for more than 12 seconds at a time, the starter motor stops automatically. Turn the key to "LOCK" position or press the engine switch to select LOCK (OFF) mode and wait for more than 30 seconds before trying again. If the engine does not start after several attempts, check the fuel and ignition system or consult a Maruti Suzuki authorised workshop.
- If the engine starts, the starter motor stops automatically.

NOTE:

- Do not press the accelerator pedal to changeover from petrol to CNG mode.

- With ignition switch "ON" and engine not running, blinking of CNG malfunction warning lamp indicates that fuel lid is open. Vehicle will not start in this condition. For details on CNG malfunction warning lamp, refer to "Instrument cluster" section in this manual.

SELECTOR SWITCH POSITION

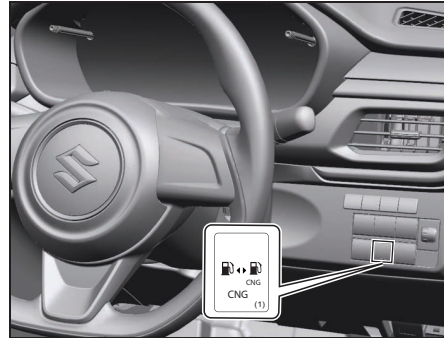

66TMC205

PETROL MODE

Type A

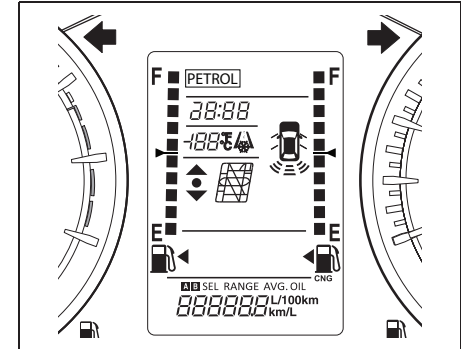

66TMC002

Type B

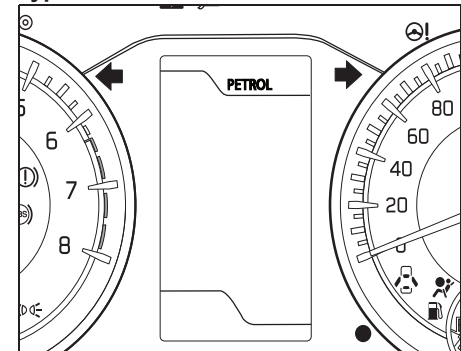

66TMC003

FOR VEHICLES FITTED WITH CNG FUEL SYSTEM

In this mode vehicle starts in petrol and continues to run in petrol mode. In this mode, petrol indication is continuously displayed in instrument cluster and CNG indication will remain off.

AUTO MODE

Type A

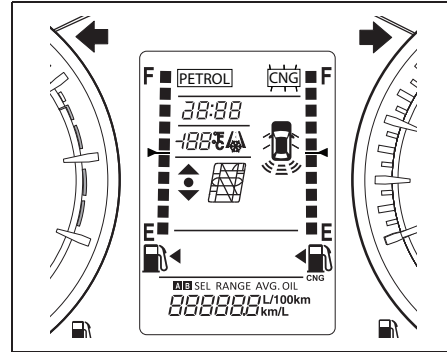

66TMC004

Type B

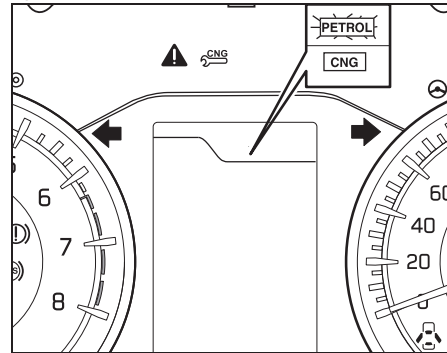

66TMC005

In this mode, engine starts in petrol mode and then automatically changes to CNG mode after reaching programmed warming up condition.

Type A - With ignition switch ON and vehicle started in "AUTO MODE", CNG indicator blinks on the display and PETROL indicator is displayed. After changeover to CNG, CNG indicator will be displayed and PETROL indicator will switch OFF automatically.

Type B - With ignition switch ON and vehicle started in "AUTO MODE", initially PETROL indicator blinking is displayed. After changeover to CNG, CNG indicator will be displayed and Petrol indicator will switch OFF automatically.

NOTE:

- It is always recommended to start the vehicle in AUTO MODE or PETROL MODE to enhance the engine life.
- The fuel changeover to CNG may not happen if the vehicle is started when the ambient / engine temperature is below Zero Degree Celsius. In such a case, run the engine in PETROL MODE till it warms up and then try restarting the engine to changeover to CNG.

FORCED CNG MODE

Type A

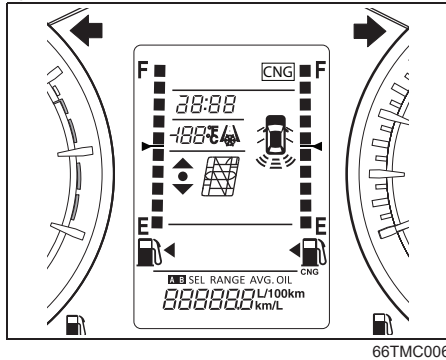

Type B

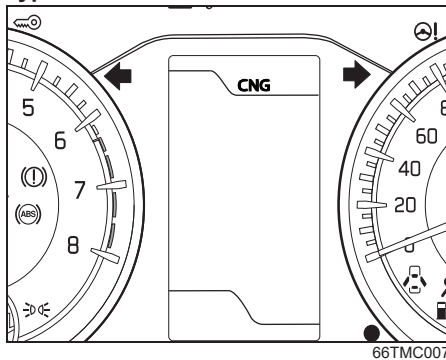

This is an emergency mode and may be used in cases where there is no petrol in the petrol tank. In this mode, vehicle starts in CNG mode and continues running in CNG mode. With ignition "ON" and engine not running, press and hold the change-over switch till only CNG indicator is displayed. In this mode, CNG indicator is displayed and PETROL indicator remains "OFF".

NOTE:

- It is recommended to keep sufficient amount of petrol in the petrol tank.
- The vehicle may not start in Forced CNG mode if the ambient / engine temperature is below Zero Degree Celsius. It is recommended to start the vehicle in Auto mode.

CNG LEVEL INDICATOR

Type A

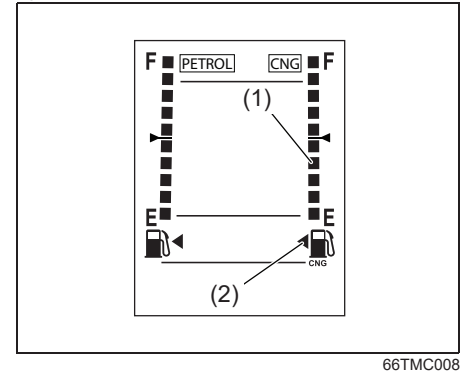

Type B

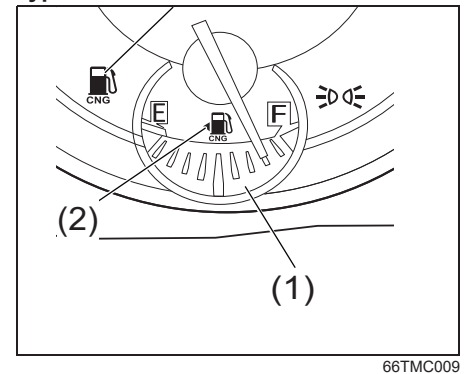

FOR VEHICLES FITTED WITH CNG FUEL SYSTEM

Type A- CNG level indicator (1) is built into the display.

Type B- CNG level indicator (1) is available below tachometer.

When the ignition switch is in the "ON" position, this gauge gives an approximate indication of the quantity of CNG fuel in the CNG tank. "F" stands for full and "E" stands for empty.

If the CNG level indicator shows only one segment to "E", refill the CNG tank as soon as possible.

NOTE:

- If the CNG low fuel warning light (3) comes on, fill the CNG tank immediately.
- The mark (2) indicates that the fuel filler door is located on the left side of the vehicle.
- For Type A - If the last segment blinks, it means that the fuel is almost empty.

AUTOMATIC CHANGEOVER FROM CNG MODE TO PETROL MODE

If CNG is finished while the engine is running, vehicle will automatically changeover from CNG mode to Petrol mode & CNG malfunction warning lamp will start blinking. Petrol indicator will be displayed continuously and CNG indicator will switch OFF automatically.

To acknowledge this information, press the changeover switch once. The CNG malfunction warning lamp will stop blinking after the changeover switch is pressed and petrol indicator will be displayed continuously. However the CNG malfunction indicator lamp will continue to blink after every subsequent Ignition ON - Ignition OFF condition until the vehicle is refilled with CNG.

NOTE:

- It is recommended to keep sufficient amount of petrol in the petrol tank to prevent engine stalling while automatic changeover from CNG mode to Petrol mode.
- In case the CNG malfunction warning lamp does not stop blinking after pressing the changeover switch, take the vehicle to the nearest Maruti Suzuki authorised workshop.

CNG FILLER VALVE

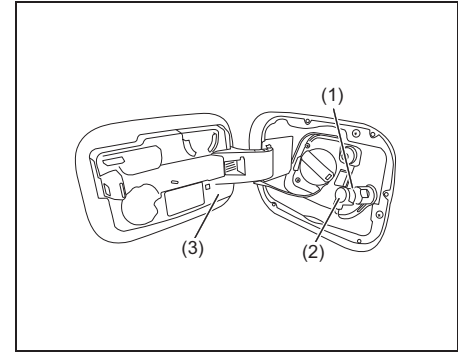

66TMC217

The CNG filler valve is integrated in fuel box next to petrol fuel filler cap.

CNG filler valve (1) can be uncovered by pulling out the filler valve cover (2) and it can be covered by simply pushing it back.

Filling automatically gets cut off when the cylinder pressure becomes equal to dispenser pressure. After CNG filling, ensure that the filler valve cover (2) and fuel filler lid (3) is closed.

NOTE:

- If the fuel filler lid (3) is kept open, you will not be able to start the vehicle.
- Engine will stop if the fuel filler lid (3) is opened in vehicle stationary condition.

CNG CYLINDER

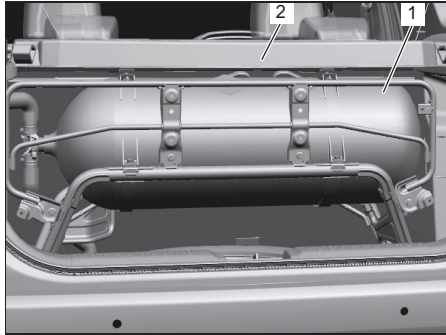

66TMC208

CNG cylinder (1) is installed in the luggage compartment below luggage shelf (2).

Luggage shelf (2) above CNG cylinder may be used for keeping lightweight luggage.

CAUTION

- Do not place any luggage or load between luggage shelf and cylinder as it may damage the cylinder, pipe, hose, valve etc.
- Do not place any heavy luggage or load over luggage shelf as it may damage it.

CNG CYLINDER WARNING LABEL

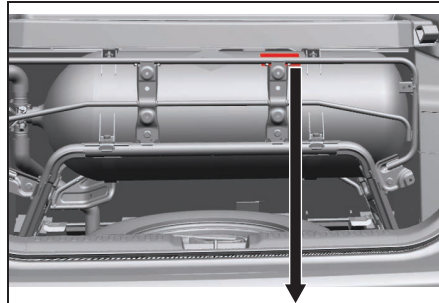

WARNING

- Do not change the colour of this cylinder.
- Do not fill this cylinder with any other gas than CNG.
- No flammable material should be stored in the close vicinity of this cylinder or in the same room in which it is kept.
- No oil or similar lubricant should be used on the valves or other fittings of this cylinder.
- Have this cylinder tested every 3 years after the date of last test.

66TMC206

You may find this label on the CNG cylinder.

MANUAL SHUT-OFF VALVE

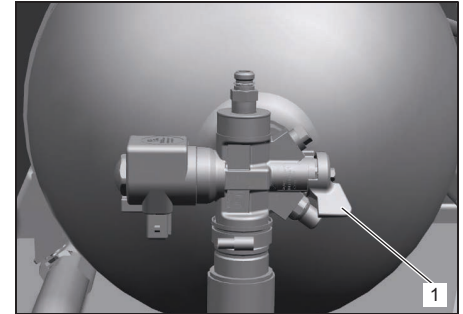

66TMC204

Manual shut-off valve (1) is located on the left hand side of the CNG cylinder.

MANUAL SHUT-OFF VALVE OPERATION

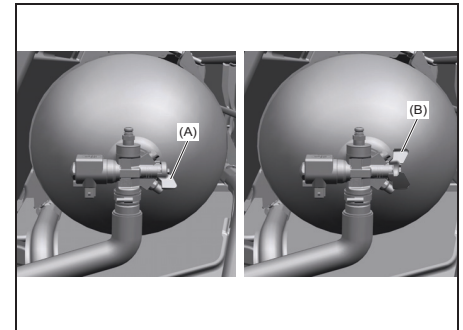

66TMC203

FOR VEHICLES FITTED WITH CNG FUEL SYSTEM

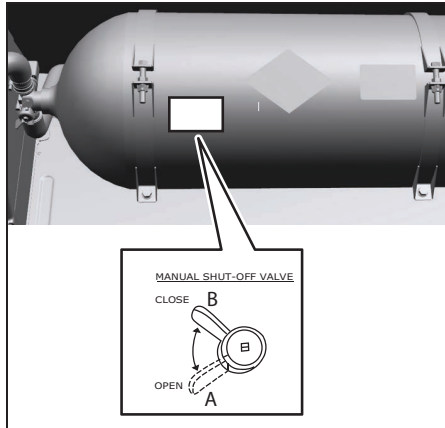

CNG supply can be switched off by closing the manual shut-off valve.

Valve closing: Turn the knob from position (A) to position (B) in clockwise direction to close the CNG supply to engine.

Valve opening: Turn the knob from position (B) to position (A) in anti-clockwise direction to open the CNG supply to engine

NOTE:

- If the manual shut-off valve is not opened fully, then the engine may not run properly.

- If the manual shut-off valve is in closed condition, it is not possible to fill CNG into the cylinder.
- As per Government regulation, CNG cylinder needs to be checked and certified every three (3) years from the date of initial testing as mentioned on the CNG cylinder identification plate. For details on CNG cylinder identification plate, refer to "Kit identification" section in this manual.
- Customer has to present the vehicle to a government approved testing agency.
- Failure to test the cylinder may result in denying of CNG filling by the CNG dispensing stations or may result in confiscation of the vehicle by enforcement authorities.
- All the expenses for CNG cylinder testing has to be borne by the customer.
- As per Government regulation, CNG cylinder has to be discarded at 20 years from the date of initial testing as mentioned in the CNG cylinder identification plate.
- Customer has to discard the cylinder at his / her expense through government approved scrap agencies.
- No person shall refill any cylinder, which has been repaired under sub-rule (2) with any gas unless a full report on the repairs and test carried out on the cylinder, accompanied by the repairer's certificate of testing are furnished to the Chief Controller and his permission is obtained for its refilling.

⚠ WARNING

- Never remove the cylinder valve from the cylinder assembly. For any assistance consult Maruti Suzuki authorised workshop.
- Never try to clean the cylinder. In case of any problem, contact Maruti Suzuki authorised workshop.
- Do not reuse the cylinder valve, once it is replaced / removed from cylinder assembly.
- Even if the CNG from the cylinder is consumed till engine stops, some amount of CNG will be left out in the tank under pressure.

LIST OF GOVERNMENT APPROVED CNG CYLINDER TESTING STATIONS

To obtain testing stations information visit the following internet website address "www.peso.gov.in"

SPARE TIRE REPLACEMENT

The spare tire is stowed under the rear floor.

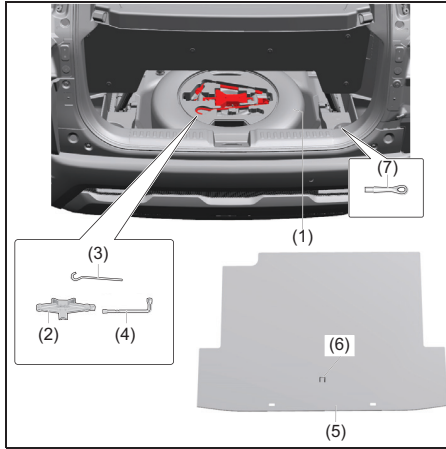

66TMC2012

- (1) Spare tire
- (2) Jack
- (3) Jack handle
- (4) Wheel Brace
- (5) Luggage Compartment Board
- (6) Strap
- (7) Towing eye

The tire changing tools are stowed in the luggage compartment below the luggage compartment board. To remove the spare tire:

- 1) Open the luggage board cover (5) by pulling the strap (6) upwards.
- 2) Place the luggage board cover (5) over the top of luggage board to access CNG cylinder compartment.

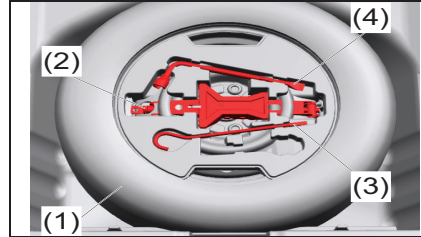

66TMC213A

To remove the jack, hold the tire changing tool storage with one hand while pulling the jack from the centre as shown in the below illustration.

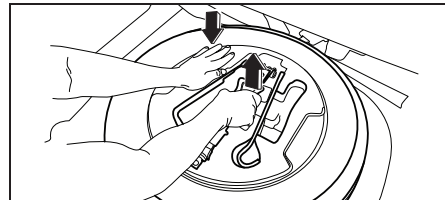

66TMC213

⚠ WARNING

After using the tire changing tools, be sure to stow them securely or they can cause injury if an accident occurs.

⚠ CAUTION

The jack should be used only to change wheels. It is important to read the jacking instructions in this section before attempting to use the jack.

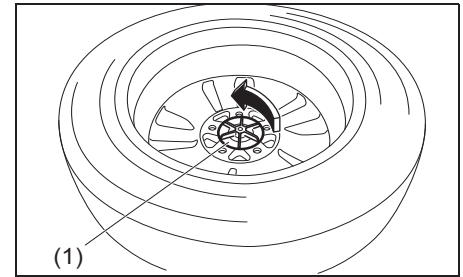

To remove the spare tire, turn its holder bolt (1) counterclockwise and remove it. While replacing alloy wheel make sure to remove the wheel cap before keeping the tire in the trunk. the tire changing tools,

NOTICE

Be sure that spare tire does not move after tightening the holder bolt. Loosely fixed tire may cause noise during driving.

FOR VEHICLES FITTED WITH CNG FUEL SYSTEM

KIT IDENTIFICATION

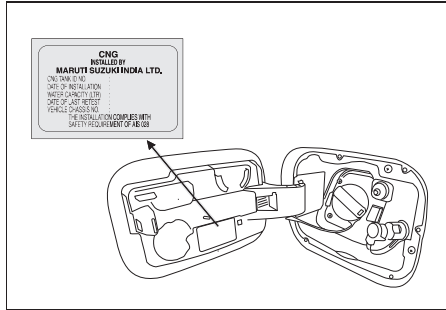

72RMC007

CNG cylinder identification number and CNG kit installation date is mentioned on the CNG cylinder identification plate located inside fuel filler lid.

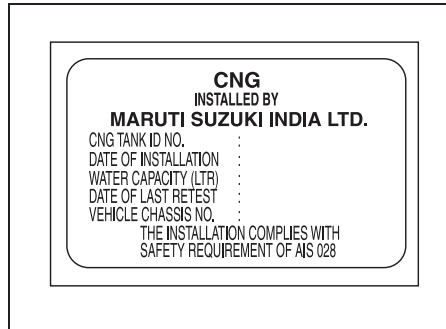

53MHMC017

CNG WARNING LABEL

Front Driver Door

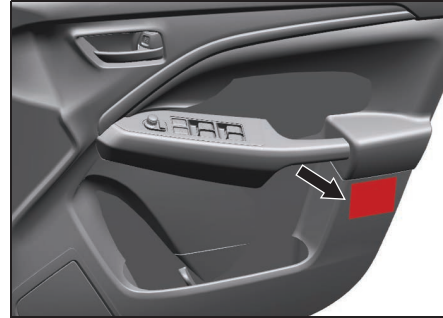

66TMC202

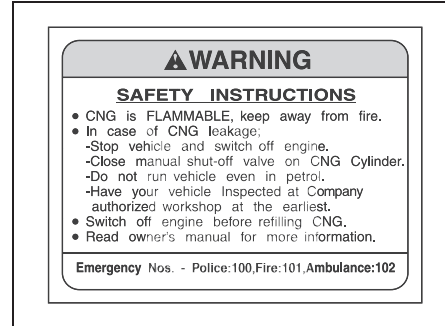

66TMC209

CNG warning label is located on front right door.

LUGGAGE COMPARTMENT HOOK

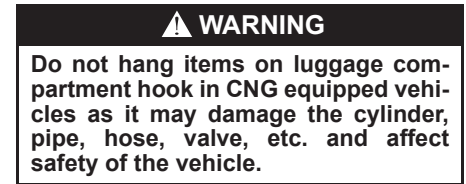

INSTRUMENT CLUSTER (Type A)

- (1) Tachometer
- (2) Speedometer
- (3) Fuel indicator (CNG)
- (4) CNG low fuel warning light
- (5) Odometer/ Tripmeter
- (6) Fuel indicator (Petrol)
- (7) CNG malfunction warning indicator lamp
- (8) Other warning and indicator lamps (If equipped)

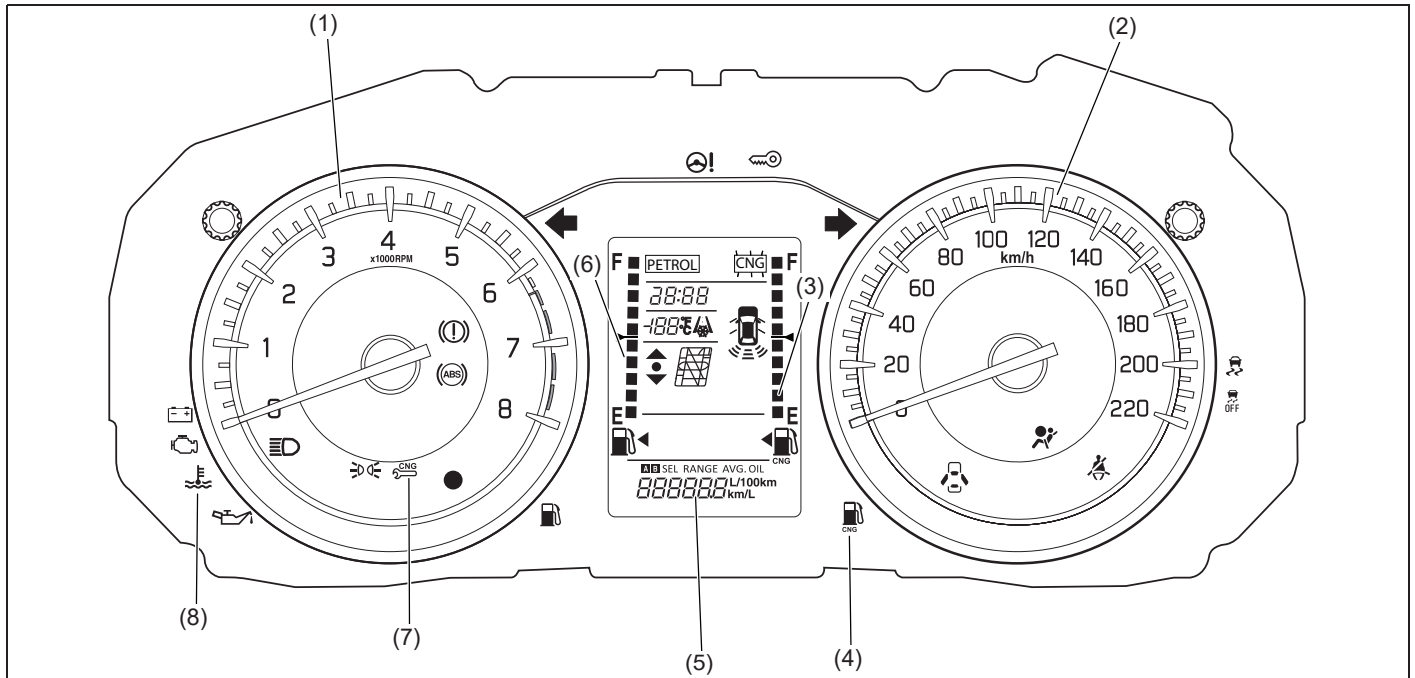

FOR VEHICLES FITTED WITH CNG FUEL SYSTEM

INSTRUMENT CLUSTER (Type B)

- | | |
|--|--|
| (1) Tachometer | (6) CNG low fuel warning light |
| (2) CNG malfunction warning indicator lamp | (7) Other warning lights (If equipped) |
| (3) Speedometer | (8) Indicator selector knob |
| (4) Fuel gauge (Petrol) | (9) Tripmeter selector knob |
| (5) Fuel gauge (CNG) | (10) TFT display |

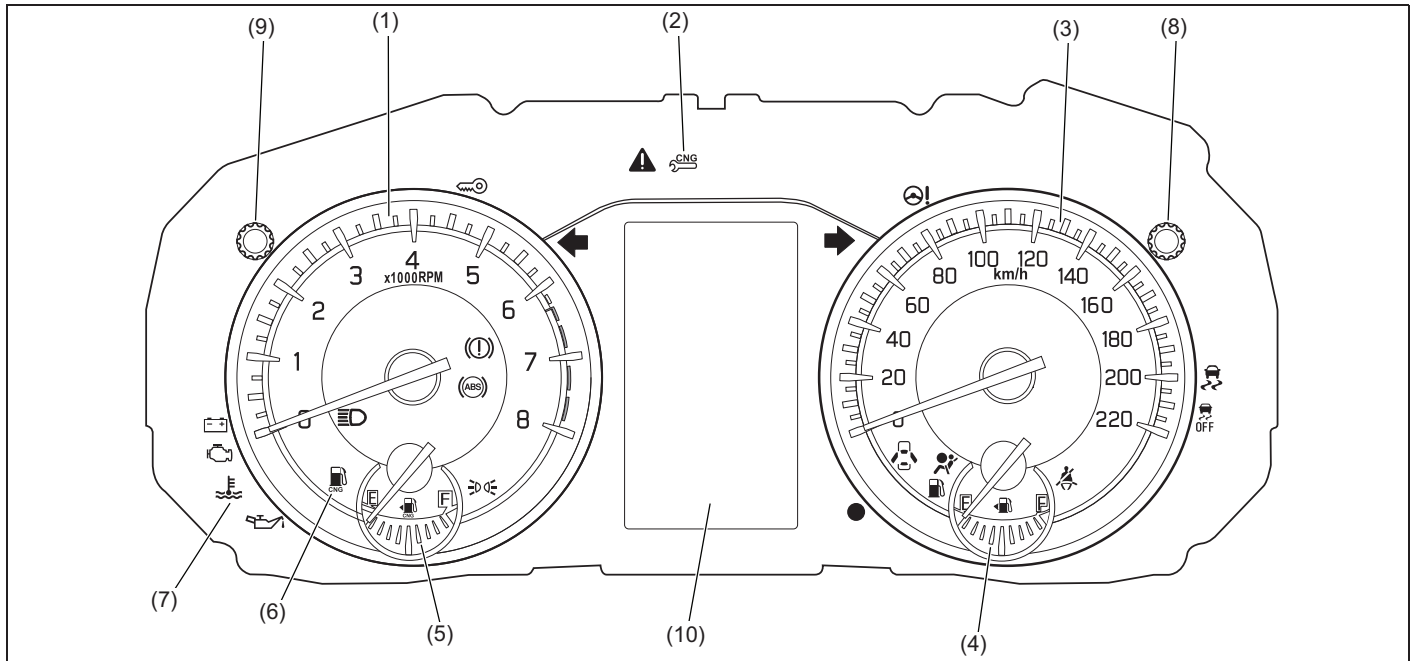

66TMC011

CNG MALFUNCTION WARNING LAMP

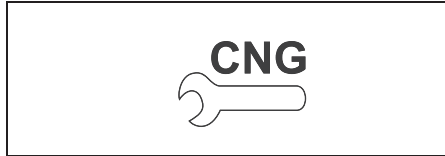

53MHMC015

When the ignition switch is turned "ON", this CNG malfunction warning lamp comes on briefly, to check that the CNG malfunction lamp is trouble free.

- If CNG malfunction warning lamp glows continuously, with ignition "ON" there is some problem with the CNG system. Immediately get your vehicle checked by Maruti Suzuki authorised workshop.
- If CNG malfunction warning lamp blinks during engine running, it means there is some problem in CNG system in which vehicle cannot continue running in CNG-MODE and automatically switches over to petrol mode. Have your vehicle checked at a Maruti Suzuki authorised workshop.

NOTE:

With ignition switch "ON" and engine not running, blinking of CNG lamp indicates that fuel lid is open. Vehicle will not start in this condition. Close the lid in order to start the vehicle.

CNG INFORMATION DISPLAY

Mode ratio and total CNG mode time:

The display shows mode ratio of CNG/ Petrol and total CNG mode time. Mode ratio and total CNG mode time will be reset by pushing and holding the indicator selector knob (8) when the display indicates mode ratio

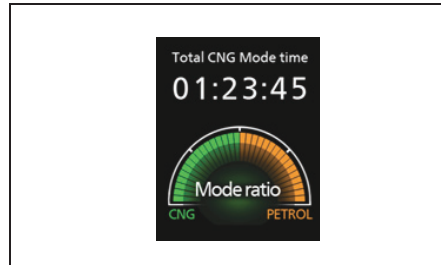

66TC0010

CNG gauge and total CNG mode time:

The display shows CNG gauge and total CNG mode time.

Total CNG mode time can not be reset when the display indicates CNG gauge. If you want to reset it, change to mode ratio display.



66TC0011

NOTE:

When Ignition mode is ON, Instantaneous fuel consumption, Average fuel consumption and Driving range information will not be displayed on information display.

FOR VEHICLES FITTED WITH CNG FUEL SYSTEM

Information shown after driving:

When you press Engine Switch to change Ignition mode to "LOCK" (OFF) while in Auto mode or Forced CNG mode, then Driving range will be shown as "---" in displayed information.

If you change Ignition mode to "LOCK" (OFF) while in PETROL mode, Driving range will be shown in displayed information.

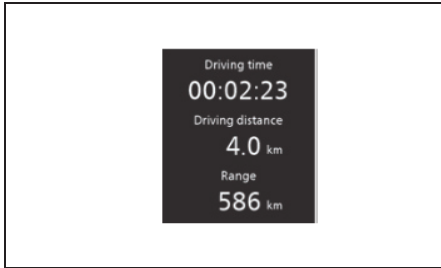

66TC0012

CNG LOW FUEL WARNING LIGHT



69RM0028

If this light comes on, fill the CNG tank immediately.

When this light comes on, a ding sounds once to remind you to fill the fuel.

If you do not fill the fuel, a ding sounds every time when the ignition switch is turned to "ON" position.

FUSES

Fuses in engine compartment

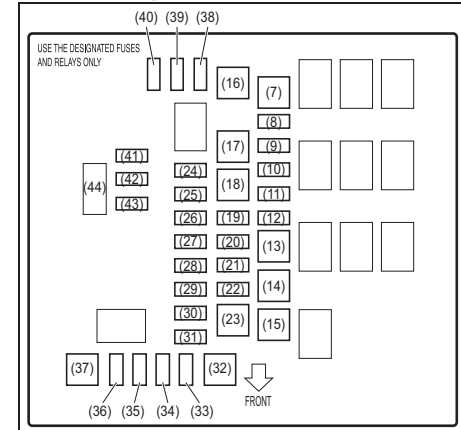

81RM06008

(22)	7.5A	CNG valve
(25)	7.5A	CNG

For other fuses, refer "Inspection and maintenance" section in the main owner's manual.

Fuses under dashboard

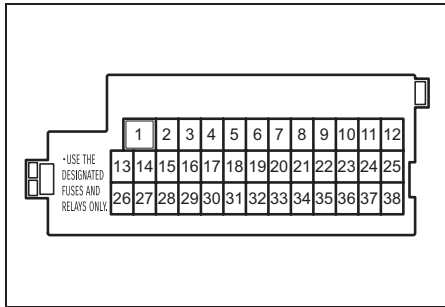

80P0185

(15)	5A	CNG ignition-1
------	----	----------------

For other fuses, refer "Inspection and maintenance" section in the main owner's manual.

FOR VEHICLES FITTED WITH CNG FUEL SYSTEM

PERIODIC MAINTENANCE SCHEDULE

Kms (1 x 1000) Month	1	5	10	20	30	40	50	60	70	80	90	100
Spark Plug (CNG)	Replace every 50,000 Kms or 48 months whichever comes first											
All Joints (Gas leakage)	I	I	I	I	I	I	I	I	I	I	I	I
Coolant Hoses (Leakage, Damage)	I	I	I	I	I	I	I	I	I	I	I	I
All Fasteners Torque values	T	T	T	T	T	T	T	T	T	T	T	T
CNG low pressure filter cartridge with O-Ring	-	-	-	R	-	R	-	R	-	R	-	R
CNG cylinder leak testing and certification	Every 3 years from the date of initial testing by govt. approved testing agency											
CNG filler receptacle O-Ring	Replace every 4 years or 300,000 Km, whichever comes earlier											

TTighten to Specified Torque

I Inspect and correct or replace if necessary

R Replace

NOTE:

- This table includes services as scheduled up to 100,000 km mileage. Beyond 100,000 km, carry out the same services at the same intervals respectively.
- For other maintenance details refer "Inspection & Maintenance" section in main Owner's Manual.

FOR VEHICLES FITTED WITH CNG FUEL SYSTEM

SPECIFICATIONS

Mass (Weight) (Kg)		
Curb mass (weight)		1230-1260
Gross vehicle mass (weight)		1680
Permissible maximum Axle Weight	Front	890
	Rear	900
Seating Capacity		5 persons
Fuel Capacity (litre)		
Petrol		48L
CNG (Water Filling Capacity)		55L

NOTE:

Specifications are subject to change without notice.

NOTE:

- 1) It is recommended to run the vehicle on petrol mode for 5~10 km after every 300~500 km run in CNG mode to keep fuel system in good condition.*
- 2) Always keep minimum 5 litre of petrol in your petrol tank.*

FOR VEHICLES FITTED WITH CNG FUEL SYSTEM

FIRE EXTINGUISHER

Do's and Don'ts

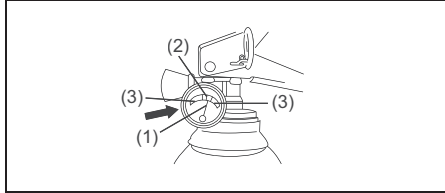

53MHMC021

Do's

- Check pressure gauge periodically. Max charging pressure is 15Kgf/cm² (in green zone (2)).
- When pressure drops, indicator needle(1) will shift to the red zone (3).Immediately contact the fire extinguisher manufacturer as per the information provided on the fire extinguisher.
- Get the fire extinguisher serviced only through the manufacturer service centre.Refer the information provided on the fire extinguisher to locate the nearest service centre.
- Ensure that the Fire extinguisher is always kept at its prescribed position in the vehicle.
- Refill the fire extinguisher immediately after use.

Don't

- Do not use water for cleaning fire extinguisher. (Use clean cloth for removing dust)
- Do not rely on used or discharged fire extinguisher.

Location

EXAMPLE



72SMC16

Fire extinguisher is located below front passenger seat.

Parts Description

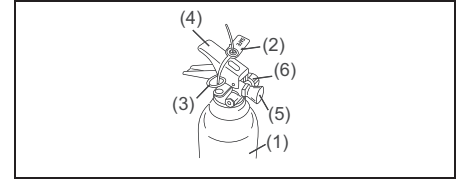

53MHMC024

- (1) Fire extinguisher cylinder
- (2) Seal
- (3) Safety Pin
- (4) Lever
- (5) Nozzle
- (6) Pressure gauge

Removal Procedure

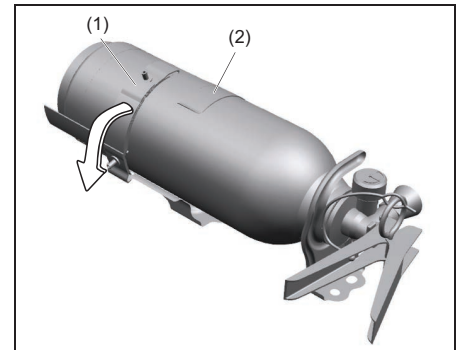

72SMC12

- 1) Pull strap (1) in arrow direction as shown in figure to untie the clamp (2).

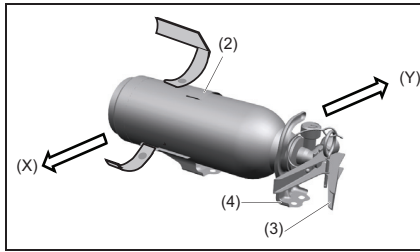

72SMC13

- 2) Remove the fire extinguisher from clamp (2) in the direction X and remove the lever (3) from the clamp (4) in the direction Y as shown in the figure.

Procedure of Operation

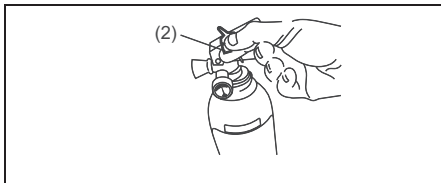

53MHMC026

1. Hold the fire extinguisher (1) upright.
2. Break seal (2) by rotating the safety pin(3).

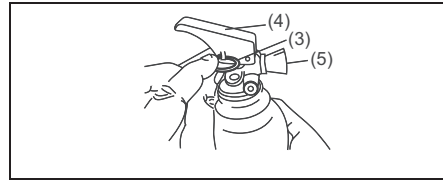

53MHMC027

3. Pull Safety pin (3)
4. Squeeze lever (4) and direct the jet from nozzle (5) towards the near edge of the fire with a rapid (fast) sweeping motion.



53MHMC028

5. Drive the fire towards the far edge until flames are extinguished.

NOTE:

Fire extinguisher is only meant for small fire caused in vehicle by external source only.

Fitment Procedure

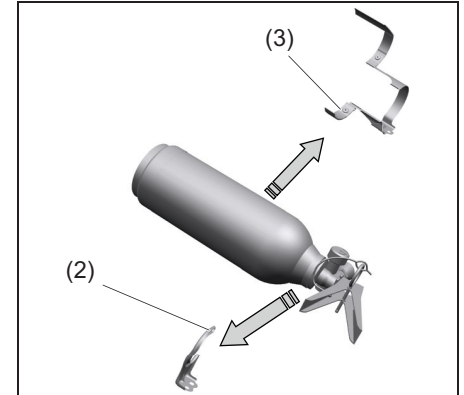

72SMC14

- 1) Insert the fire extinguisher carefully into both clamps in the direction as shown in the figure.
- 2) Tie the strap (3) and ensure that fire extinguisher is fixed securely.

FOR VEHICLES FITTED WITH CNG FUEL SYSTEM

WARNING

Ensure that fire extinguisher is securely fixed into both the clamps. Otherwise, it may come from the clamps inadvertently that may cause injury.

NOTE:

Ensure that the nozzle of fire extinguisher is properly seated on the clamp.

Refilling Schedules

1. Refilling is necessary after every use.
2. Fire extinguisher needs refilling after every 3 years even if it is not used.
3. Get the fire extinguisher inspected every 6 months through the authorised service center of fire extinguisher manufacturer

Prepared by
MARUTI SUZUKI INDIA LIMITED

Service Division
February, 2025

Part No. 99011M66TC1-74W
Printed in India

**For round-the-clock on-road assistance,
call Maruti On-road Service at 1800 102 1800[#] / 1800 1800 180[#]**

No STD code to be prefixed.

 **MARUTI SUZUKI**
GENUINE ACCESSORIES

 **MARUTI SUZUKI**
GENUINE PARTS

 **MARUTI SUZUKI**
COST PROTECT

 **MARUTI SUZUKI**
HELPLINE

 **MARUTI SUZUKI**
ROAD SERVICE

SERVICE DIVISION
MARUTI SUZUKI INDIA LIMITED
Palam-Gurgaon Road, Gurgaon – 122 015 (Haryana), India
Visit us at: www.marutisuzuki.com